

MYST[®]

V

END OF AGES

PRIMA Official Game Guide

Bryan Stratton
Katherine "Khatie" Postma

Table of Contents

<i>Letter from the Author</i> _____	3	<i>Behind the Scenes of</i>	
<i>The Journey Begins</i> _____	4	<i>Cyan and Myst V</i> _____	185
<i>Tahgira</i> _____	20	<i>Tim Larkin</i> _____	185
<i>Todelmer</i> _____	46	<i>Ryan Miller</i> _____	186
<i>Noloben</i> _____	75	<i>Ryan Warzecha</i> _____	187
<i>Laki'ahn</i> _____	101	<i>Eric Anderson</i> _____	188
<i>The End of the Journey</i> _____	124	<i>Josh Staub</i> _____	189
<i>Yeesha's Journals</i> _____	138	<i>Bill Slease</i> _____	190
<i>Quick Reference</i> _____	150	<i>Richard "RAWA" Watson</i> _____	191
<i>The Myst Mythos</i> _____	175	<i>Rand Miller</i> _____	193

Prima Games
A Division of Random House, Inc.

3000 Lava Ridge Court, Ste. 100
Roseville, CA 95661
1-800-733-3000
www.primagames.com



The Prima Games logo is a registered trademark of Random House, Inc., registered in the United States and other countries. Primagames.com is a registered trademark of Random House, Inc., registered in the United States.

© 2005 by Prima Games. All rights reserved. No part of this book may be reproduced or transmitted in any form or by any means, electronic or mechanical, including photocopying, recording, or by any information storage or retrieval system without written permission from Prima Games. Prima Games is a division of Random House, Inc.

Product Manager: Damien Waples

Editor: Rebecca Chastain

Design: José de Jesus Ramirez

Layout: Keating Design

© 2005 Ubisoft Entertainment. All Rights Reserved. Based on Myst® and Riven® created by Cyan Worlds, Inc. © Cyan Worlds, Inc. All Rights Reserved. Ubisoft, Ubi.com, and the Ubisoft logo are trademarks of Ubisoft Entertainment in the U.S. and/or other countries. D'ni™, Cyan®, and Myst® are trademarks of Cyan, Inc. and Cyan Worlds, Inc. under license to Ubisoft Entertainment. Developed by Cyan Worlds, Inc.

All products and characters mentioned in this book are trademarks of their respective companies.

Please be advised that the ESRB Ratings icons, "EC," "E," "E10+," "T," "M," "AO," and "RP" are trademarks owned by the Entertainment Software Association, and may only be used with their permission and authority. For information regarding whether a product has been rated by the ESRB, please visit www.esrb.org. For permission to use the Ratings icons, please contact the ESA at esrblicenseinfo.com.

Important:

Prima Games has made every effort to determine that the information contained in this book is accurate. However, the publisher makes no warranty, either expressed or implied, as to the accuracy, effectiveness, or completeness of the material in this book; nor does the publisher assume liability for damages, either incidental or consequential, that may result from using the information in this book. The publisher cannot provide information regarding game play, hints and strategies, or problems with hardware or software. Questions should be directed to the support numbers provided by the game and device manufacturers in their documentation. Some game tricks require precise timing and may require repeated attempts before the desired result is achieved.

ISBN: 0-7615-5137-9

Library of Congress Catalog Card Number: 2005923803

The authors would like to thank:

From Cyan: **Rand Miller, Chris Brandkamp, Tim Larkin, Ryan Miller, Richard Watson, Ryan Warzecha, Eric Anderson, Josh Staub, and Bill Slease**

From Ubisoft: **Ashley Bushore, Yan Charron, Sarah Berridge, and Ron Meiners**

From the *Myst* fan community: **Lucille "Memiki" Cali, Andrew "Deg" Chernauskas, Larry "Rex Havoc" Brown, Gary "Alahmnat" Budell, Cate "Jerle" Fagan, Ian "Navah" Gazzotti, Matt "EatMyShorts" Giuca, Brian "SR388" Hagan, Keith "Tweek" Lord, Amberle "Saphira" Matthews, Marcel Paans, Joe "RRCAZ" Pedrosa, Rick "Timeposter" Postma, John Rizzo, Daniel "Dan'ni" Sadowski, Bryan "Blue Max" Siegfried, and Roy "LRBolt" Smith**

From Prima: **Damien Waples, Rebecca Chastain, Asha Johnson, and Andy Roller**

A special thanks to: **Steve Stratton, David Hodgson, and Holly Hannam**

18 July 2005

Hey all,

Please pardon the handwritten letter, but considering the subject at hand, it only seemed fitting for me to put an ink pen to an actual sheet of pressed wood pulp paper. Katie Postma, a D'ni scholar from the Richard A. Watson Institute, sent the pen and paper along as a gift after proofing the manuscript. I tried to tell her that the sidebars that she added to the text were enough of a gift, but she would have none of it.

Anyway, thanks for all of your support in making this book happen. If there's one thing I've learned in my travels, it's that books hold power...certain books in particular. I know that it wasn't easy to convince the higher-ups to go for it. If they actually get around to reading what I've written, there won't be any doubt in their minds that I've lost mine. But it's all true, I swear it.

I'm still disappointed that the book is going to be published as a work of fiction, but I understand that you've already pulled as many strings as you can, and I appreciate it. Those who feel called to the Quest will realize the truth, and those who don't will get a good story out of it, at least.

Best,
Bryan

The Journey Begins

What Has Come Before

I have always been an explorer. My natural curiosity, encouraged by those around me in childhood, blossomed into an overpowering desire to learn as much about the world around me as possible. Every mystery or unanswered question I have encountered has always seemed like a personal challenge, and few things delight me more than successfully testing myself against the unknown and peeling back its mysteries. As society continues its reckless race toward the future, I find myself drawn ever more strongly to the past. But, anachronistic as they are in this digital age, I have always loved books.

In fact, it was my love for the printed word that ultimately led me to the journey I am about to embark upon. My research into the rumors of a hidden underground city underneath the New Mexico desert began as a teenager as I played through the **Myst** series of games. The funny thing was, I didn't know that they were more than just games. Upon first glance, I thought that they were simply meant as amusing diversions and nothing more, and I wasn't alone in this assumption.

The Lost Children of D'ni

Although considered "fantasy" and "fiction" by many throughout the world, the tales of Myst in games and novels were soon recognized by one part of the population as more than just pleasant diversions. The stories deeply resonated with these people as something more than just a tale.

In fact, certain members of the D'ni Restoration Council (DRC) believe that many of these people are the distant descendants of ancient explorers that came to the surface from D'ni thousands of years ago. Whether that belief is correct or not, it is undeniable that something was "awakened" in many people worldwide when they first ventured into these worlds and read these stories...something that called them to D'ni.

The Journey Begins

However, an offer to meet with Dr. Richard A. Watson of the now-defunct D'ni Restoration Council (see **Uru: Ages Beyond Myst**) led me to realize that they were not merely works of fiction. Instead, they were a representational documentation of an actual society that existed on earth for thousands of years, until its cataclysmic destruction approximately 200-300 years ago.

Note

See the "Myst Timeline" appendix of this journal for more information.

My research began with the events detailed in the first **Myst** "game," the most popular interactive entertainment of its time. Using a fantastic "Linking Book" that permits instantaneous travel across time and space, a traveler arrives on a mysterious island at some point in the 19th century. There, the traveler rescues Atrus, one of the last of the D'ni, a human-like race from a cavernous city deep underneath the surface of the earth. Like his D'ni ancestors, Atrus is a master of the Art of Writing, allowing him to create Linking Books that lead to an infinite variety of Ages. Two of these Ages become prisons for Atrus's sons, Sirrus and Achenar, for their crimes against the peoples of several other Ages.

Five years later, the traveler returns to help Atrus rescue his wife, Catherine, from the clutches of Atrus's twisted father, Gehn. In doing so, Catherine's home Age of Riven is destroyed, and Gehn is presumably killed in Riven's death throes. (The complete story is recounted in **Riven**, the "sequel" to **Myst**.)

After Catherine's rescue, Atrus turns his efforts to rebuilding D'ni. Atrus lives in relative peace for a decade before his efforts are interrupted by Saavedro, a bitter survivor of an Age destroyed by Sirrus and Achenar. Again, Atrus relies on the help of his anonymous "friend" to stop Saavedro and rescue Atrus's family, which by this point includes a infant daughter, Yeesha. The scholars of the time referred to this story as **Myst III: Exile**.

Twenty years after **Myst**, Sirrus and Achenar break free from their prison Ages. Both are initially treated as threats to their family, but it is revealed that Sirrus is the sole menace, while Achenar has legitimately rehabilitated himself. Atrus's anonymous "friend" from the first three stories helps Achenar to save Yeesha from Sirrus's clutches. By the end of the story (referred to as **Myst IV: Revelation**), Sirrus and Achenar are dead. Neither Atrus, Catherine, nor their "friend" reappears in the **Myst** stories from this point on.

Answering the Call

Atrus is a man about whom much has been studied, written, and discussed. He is quiet, deep-thinking, and kind. Many who meet him, including the stranger long ago, feel compelled to help this man who was born into a strange, mixed, and often dysfunctional family. Through the madness and grief that has become the backdrop of so much of Atrus' family history, he alone is the sane, hopeful one who encourages and supports the peaceful restorative efforts to create a new home for D'ni and all its descendants.

Why do we help him? We may never fully understand the answer. What we do know is that we must. It is in us to give back something to this man, this legendary figure who spent his life trying to save others.

There is little to no information about what happened in D'ni over the course of the next two hundred years, save for a handful of apocryphal texts that were published as printed works of fiction. It is widely speculated that Atrus abandoned his goal of restoring D'ni.

The story resumes at the very end of the 20th century, with the discovery of the ruins of D'ni by human explorers. I am proud to count myself among their number: I presented these archaeological findings as the **Uru** series of travel guides. (The D'ni word "uru," means "deep city.") However, due to the fact that they were published under an imprint usually reserved for video game strategy guides, my books were generally viewed as fiction. What could have been the greatest archaeological find in human history was dismissed as the product of an overactive imagination.

The reconstruction of D'ni failed as a result of a conflict between two equal and opposite forces: the human D'ni Restoration Council (DRC), which viewed D'ni primarily as one large archaeological dig site; and Yeesha, who had grown up as a spiritual leader of the Bahro, a race with a history of exploitation at the hands of the D'ni. Yeesha did not want D'ni to be rebuilt if it meant that the mistakes of the past would be repeated, and the DRC would not allow Yeesha to compromise their discovery. Ultimately, neither side succeeded in its pursuits, and D'ni was abandoned once again.

The Journey Begins

When One Door Closes...

In February 2004, the DRC announced that they had lost their funding and were forced to end their efforts for the restoration of the D'ni cavern and Ages. The collective shock and dismay of the explorers was almost tangible. The cavern, which once had been filled with the noises of work crews, journalists, and historians, had a hush in which the echoes of disbelief resonated.

One thing became evident very quickly: The new people of D'ni were not easily chased from their home. Full of renewed vigor and determination, these explorers mounted many campaigns to keep the research and exploration going.

Today, hundreds of D'ni enthusiasts still visit the cavern together. In pairs or in small groups, they come to reminisce, experiment, and discover. Thanks to the cooperation of so many working together, the dream of visiting D'ni lives on.

That was several years ago. Since I began researching D'ni, I have followed thin threads of rumor and legend, searching for the answers to the questions left by the collapse of the DRC and the disappearance of Yeesha. And today, after years of fruitless searching, I have decided to use a Linking Book to the K'veer section of D'ni itself. The risks of undertaking such an exploration alone into the unknown are many, but I can no longer stand the nagging questions that plague my every waking moment. This journal serves to recount my experiences for any explorers who choose to follow my path.

I do not know what awaits me. I only know that I cannot abandon this journey.



K'veer Prison

I had almost forgotten the indescribable sensation of linking. For a moment, I was between two worlds, two Ages. But the shock of my first linking paled in comparison to the sight that greeted me when I arrived in K'veer. Upon my appearance, several dark humanoid creatures scurried along the walls and ceiling into the shadows, disappearing from view. From my research, I recognized them as the Bahro, often referred to by

Yeesha as "the Least." I recalled that several of them were released from a prison Age by the Uru explorers of the DRC, but no mention was made of what had happened to them afterward. I was relieved to see that these Bahro seemed more inclined to run, rather than confront me.



Could these be the Bahro?

The Bahro

The fact that the Bahro just scuttle away and then "vanish" indicates an amazing ability to link at will, even without Books or linking stones. This ability is both impressive and alarming. It is impressive because it is not an ability one would expect from a creature. It is alarming, however, because it means that at any moment, in any place, and without any warning, we may be visited by them again.

It also makes one ponder what other abilities the Bahro might have....

After the Bahro disappeared, I took a look at the room I'd linked into, Atrus's prison in the K'veer section of D'ni, where his anonymous "friend" had first met him at the conclusion of **Myst**. It was also where my final **Uru** story ("The Path of the Shell") had concluded. I found Atrus's Myst Linking Book on a pedestal, but the book was locked securely and resisted all attempts to open it.

The Journey Begins



The Myst Linking Book was locked.

Only one of the room's seven doors had a functioning handle on it. I grasped the handle and pulled down on it to open the door and proceed down the corridor beyond it in the only direction possible. After several flights of stairs, I found a journal and a D'ni camera. I found that the pictures I took with the camera instantly appeared in this journal, something I was sure was going to be of great help in my journey.



A D'ni journal and camera

I continued down the corridor beyond the D'ni journal and camera. The corridor ended in a large, open room. Several more Bahro scampered for the shadows and linked away as I entered. My attention was drawn to a large, shimmering bubble at one end of the room. Constantly changing images of four different Ages appeared along the inner wall of the bubble's surface. Inside the bubble was a translucent Tablet, held in place by four stone locks. As I reached out to touch it, it quickly turned solid and changed back again. There was also a noise, as if I had triggered something.

Yeesha



The Tablet

I stepped out of the bubble and was startled by the sudden appearance of a woman behind me. It took me a second to realize that this was Yeesha, daughter of Atrus and Catherine. If the dates of the legends were true, she would have to be about 200 years old, long-lived even by D'ni standards. And the lines etched into her worn visage in the handful of years since the last time I had seen her indicated it had not been an easy life.

The Sands of Time

Yeesha's face is lined and worn, similar to a well-traveled path—inviting, warm, yet marked with the evidence of thousands of journeys. How old is she? How long has it been since she was last seen by a resident of our Age? One could venture a guess, but, knowing her D'ni lineage, it would probably fall short of the mark.



Yeesha appeared after I touched the Tablet.

Without waiting for me to speak—or giving me an opportunity to ask her any questions—Yeesha gave me cryptic information about a Quest that I was to undertake. Fortunately, I had the presence

The Journey Begins

of mind to record her speech so that I could transcribe it later (see sidebar), as I failed to comprehend the full meaning of much of what she had to say. Before I could ask her to elaborate, she waved her hand, and I felt myself linking again.

Yeesha's Speech

So friend, the Tablet has responded to you. Of course.

If you're seeking my father, his time is passed. He won't be requiring your assistance. The book to his cursed island lies locked and gathering dust in his prison. That book, along with his pain and his burden, have been passed to me. And now you will know it too.

You will listen carefully. This is not to be taken lightly. The Tablet has responded to you. It will be your burden. Choose wisely in the end, for there will be no second chance. Many have taken this Tablet, and they tried not to let go. It is the power of the writing. It...seduces all who try to hold it. I have held it...tasted its sweetness. But I can hold it no longer.

They have served too long. Always serving. Ever watching. And now, perhaps, you will see how to release them.

First, collect what's been scattered, and then the Tablet will be released. Then, you will hold it.

You will find in each Age along the journey that there will be help, and there will be hindrance. You will start this journey where I started, where my father Atrus started, where my great-grandmother Ti'ana started. You will end this journey here, when the Tablet is released.

When you return, the Tablet will be yours. When the Tablet is yours...do not give it to me.

What you still don't understand, you have failed to hear or don't need to know. Begin.

The Descent

The first thing I experienced when I came through the link was a searing blast of desert heat. Before I had a chance to wonder where I was, a man appeared directly in front of me, dressed in traditional D'ni garb. He introduced himself as Esher, and while his demeanor was certainly friendlier than Yeesha's, he was nearly as enigmatic. Once again, I recorded what he had to say for transcription (see sidebar).



Esher

Esher's Speech

You have seen Yeesha. She was, I'm sure, not very hospitable. You are confused, no doubt. My name is Esher. It is my pleasure to meet you.

She has given you the Quest. Yes...the Quest. The Quest to carry the four. The Quest to release the Tablet. The Quest that is proving to be more difficult than she anticipated. Many have taken the Quest...and the Tablet still has no master.

I will tell you what she will not. I will help you when she will not. But she and I agree on this point: DO NOT give her the Tablet.

She has lied to you already...uttered words that bite her heart as they leave her lips...for she wants that Tablet...more than anything! She desires what she can no longer feel...but once tasted. You must not...whatever happens...give it to her.

Ah...she is the desert bird that longs to fly. She has dreams of taking flight in her ambiguous world filled with vague clouds and shadowed air Careful...she is a clever one.

I'm sorry. I'm overwhelming you. Look for the hole in the ground. That's where your journey begins. I will find you....

The Journey Begins

Esher told me to look for "the hole in the ground" to begin my journey, and after transcribing his speech, I did just that. I found it behind some boulders near a giant Moiety dagger, similar to the one I had seen in my studies of Riven. Yeesha said that my quest would begin where she, Atrus, and Ti'ana started their quests, which was in the New Mexico desert, at a cleft in the earth that led down to D'ni. My pulse quickened as I climbed down the rope ladder to the cavern below.

The Moiety Dagger

When Riven collapsed and the stranger was thrown into the Fissure, there was always some question as to where he might land. This question was answered in Uru, when explorers made their way to the New Mexico desert to gain entrance into D'ni. Scattered around the Cleft were relics from Riven: the telescope and the wahrk bones. Here, in the top of the volcano, is another remnant of Riven—one of the huge and impressive daggers that Catherine herself had written into Riven; the very dagger that Moiety later selected to symbolize their rebellion against Gehn. Seeing it here is a powerful reminder of what changes are wrought by those who dare to transform worlds.

Finally!

For centuries, the secret entrance to D'ni in a desert volcano has been written about and searched for, but rarely seen. At one time, followers of the DRC felt that it had been swallowed by the desert and might never be used to enter D'ni again. After all, when Yeesha was bringing explorers into D'ni, she had them link there rather than taking the long journey down through the tunnels. But it seems this passage has remained at least partially useable through time, waiting for that traveler to seek it out and explore it.

I made my way through the cavern, grateful for the shelter from the desert heat that its cool walls provided. Several more Bahro fled at my approach. As I exited the cavern, right there on the ground next to a lantern was a small bound volume, and another one just off to the right (see sidebars). I recognized the seal on the front of it as Yeesha's. The two entries within them offered some insight into her perspective, but in keeping with everything I had read about her, it raised as many questions as it answered. One thing was for sure: She viewed her father's Myst Age as a cursed place, vowing never to return to it. I tucked the journals into my satchel and continued down the dimly lit hallway, startling a couple more Bahro as I proceeded.



The rope ladder leading down into the cavern

Yeesha Journal—Prologue

These pages are my journey, my story, my path. They are not meant to cover up, but to reveal. Sometimes in poem, sometimes in story, sometimes clear, sometimes vague, sometimes long, sometimes brief. But the release of these words is a soothing elixir to my burdened soul. The words must flow from me, or I will die.



And in the end, these words are crumbs that spill along my path. And whoever eats these crumbs will know more of me.

The Journey Begins

Yeesha Journal I

I am finding where I am, by understanding where I was.

And everything I was is linked to the island of Myst—the refuge.

And I must know where they were as well. My heritage, my people, my family.

My father, the prisoner of the hidden and the revealed. Raised by Ti'ana who hid the truth. Then raised by Gehn, who revealed the truth. But Ti'ana hid for love, and Gehn revealed for power.

Mother too, nothing more than a slave to what she knew and what she felt. Taught by Gehn to write what she knew. Then taught by Ti'ana to write what she felt. But Gehn's teachings imprisoned her, and Ti'ana's teachings freed her.

And in the end, through the hidden and revealed, through the known and the felt, through the good and the evil, through the gods and the devils—they came together. Together they came: Father floating and Mother caring. Father knowing and Mother feeling.

And my great-grandmother Ti'ana watched, and my grandfather Gehn fell.

And so began our path of pain.

Ti'ana was called the destroyer, but she brought them together—and lived with them on Myst island.

Father could not keep Myst simple—new structures and new Ages he brought. Mother could not keep Myst solitary—two new sons she brought—my brothers—Sirrus and Achenar. And they grew up strong, and hungry, and lustful, like their grandfather Gehn—unable to control the power of Books—the power of writing Ages.

And as a result all became prisoners. Prisoners in their refuge.

I will never return to that place.



Rest Area A

At the end of the hallway was a crude rest area filled with inoperable D'ni artifacts. Another Bahro linked away as I entered. I found another Yeesha Journal on a cot in the center of the room and read it to learn of her wariness of the D'ni pride that ran through her bloodline (see sidebar). The last page featured a curious illustration of a pentagonal stone tablet. I recognized the shape of it; I had seen it on one of the four stone locks that secured the Tablet spoken of by Yeesha and Esher.



Another skittish Bahro

Yeesha Journal II



Pride is a thief. Pride stole the soul of the D'ni people. Pride stole my own brothers. The temptation was too great. It is not the power, but the desire for power that destroys. That desire is in my blood. The blood of my ancestors—the blood of my flesh. I fight it, but I am pulled, even now.

My father tried to hide what he valued, his Books and Ages, while my brothers tried to hide what they valued, riches and power. Father was trusting or naive and Ages and people were destroyed.

And so my family was imprisoned. My brothers in Ages written by Father; Father in a D'ni prison he had escaped from in childhood; and Mother in the world she loved and feared the most—Riven—her home—her refuge.

The Journey Begins

Perhaps it's why I now fear my home—my refuge.

And then by the Maker, or by the roll, a stranger found the Book. The Book had been intended to be destroyed by fire, but by the Maker, or by the roll, it was taken far away. The Book was preserved until it was time. Surely it was the Maker who preserved the Book that would bring help.

Now it was time. A stranger found the Book, came to the island and freed Father. A lesson was learned, a friendship was forged.

Friendship. The Least are my friends. I must use the Least wisely. I must listen to them. And respect them. They are powerful, they are willing, and they are afraid.



A Linking Book

On a pedestal near the entrance to the rest area was a Linking Book, open to its Linking Panel. The Panel showed a panoramic view of four small islands in a dark stone forest. The islands were joined by footbridges, and each island held a shimmering bubble similar to the one I'd seen in K'veer. Below the Linking Panel, I saw a sketched map of the Age that the Book linked to. The northeast island was shaded, presumably to indicate that it was the link-in point from this Linking Book. I placed my hand on the Linking Panel and linked to an Age I would come to call Direbo.

Direbo

True to his word, Esher greeted me warmly upon my arrival in Direbo, "an Age for resting," as he called it. With obvious contempt in his voice for the Bahro, he told me that the stone on the pedestal inside of the nearby shimmering bubble was a Bahro device that would link me to the first Age in my journey, Tahgira. Promising to meet me in Tahgira, Esher linked away, leaving me alone in Direbo. I transcribed my recording of his instructions (see sidebar) and explored Direbo.



Esher explains the purpose of the pedestal.

Esher's Speech

Ah-hah...Direbo. An Age for resting. Hah...such a peaceful place. And...the way to get to the first Age.

There. (indicating pedestal stone) That profane thing, and the other pedestals like it, are not of D'ni. They are a regrettable part of this journey. The pedestal will allow you to link in a manner similar to the book that brought you here. But...know this: They are perverted tools of the creatures.

The creatures...you have seen them. Always watching, calling to one another in the darkness, loathsome...wraiths. They are not as we are. Remember that.

Touch the pedestal. It will bring you to the Age of Tahgira. I will find you there.

The Journey Begins



I unlocked both bridge gates.

As it turned out, there was not much to explore. A Linking Book on a pedestal would allow me to return to the rest area I had just come from (Rest Area A). The footbridges leading to the northwest and southeast bridges had locked gates at each end. By pressing the glowing blue buttons at the ends of each of them, I unlocked the gates on my side of the bridges, but I was unable to unlock the gates

on the other side of the bridges. If I wanted to reach the southeast and northwest islands, I would have to find another way to do so.

An Age for Resting

Direbo was a world meant to serve as a rest Age for the D'ni during their journey to the surface. Rather than hole up in the carved niches along the way, the D'ni could link to this lush, green, peaceful Age and find rest and relaxation.

The Bahro placed the pedestals and their bubbles into Direbo at a much later time.



I touched the pedestal to link to Tahgira.

The pentagonal stone on the pedestal inside of the shimmering bubble was translucent. A glowing icon in the shape of the stone was etched into the pedestal. Recalling Esher's instructions, I placed my hand on the pedestal's pentagonal icon and linked to the Age of Tahgira.

Tahgira

Exiting the Ice Cave

It took me a moment to realize that I had linked to Tahgira. I reappeared in a shimmering bubble, similar to the one in Direbo. However, where the Direbo bubble had a translucent image of Tahgira's link-in point projected on the inside of it, the Tahgira bubble had a translucent image of Direbo inside it. A pedestal stood in front of me, almost identical to the one in Direbo, with the same pentagonal Slate resting upon it.

Esher stood behind me, outside of the bubble. As I stepped out of the bubble and into the frigid ice cave beyond it, he began to speak (see sidebar), telling me that Tahgira was originally designed as a prison Age. He alluded to the power of the pedestal's Slate, saying that I could take it with me and use it to control the Bahro. Before linking away, Esher told me to use the Slate to free myself.



A stone Slate on the Tahgira pedestal



Esher alludes to the power of the Slate.

Esher's Speech

I don't know why the creatures chose this place for the Slates. Tahgira. Cold, barren, desolate, it has been described. However, also...purposeful.

No doubt Yeesha sees only evil here. This was a prison Age...for those who committed monstrous crimes. They were sent to this place to live out their lives. Justice...not evil.

Much to learn. First, the stone Slate. Pick it up from the pedestal and take it with you. But know this about the Slates: They too are abominations, made by the Bahro creatures' abuse of the Art of Writing. Still...they carry great power.

You will find that you can write on the Slates, anything you wish. There are some elementary symbols the creatures understand. At least in this way, you can use the Bahro hindrance for your good.

They will take it, if you drop it. They will obey it, if you order them. They will return it, in time. As you learn, you will have more control.

Use the Slate to free yourself. The burden you carry is heavy. But for that...you will be thankful.

It didn't take long for me to realize what Esher was talking about. The mouth of the small ice cave overlooked a snowy field, but the icy incline leading up to it was too slippery to climb. The only other way out of the cave was the pedestal link back to Direbo, but that could only take me backward, not forward, in my quest.

As per Esher's instructions, I picked up the Slate from the pedestal and examined it. It was heavy enough to be made of stone, but I found that I could inscribe its surface with only a light touch of my finger. Six Slate icons decorated the bottom of the Slate. Five were blank; I couldn't venture a guess as to what they were used for. The sixth icon had two diagonal lines crossing it. When I touched this icon, the Slate was wiped clean.





The outline of the Slate on the floor of the cave

After a few brief experiments with the Slate, I began exploring my frigid prison, and that's when I saw the outline of the Slate on the floor of the cave. Having no other ideas, I stood on the outline and dropped the Slate.

As soon as I dropped the Slate, the ice underneath me started to crack! I jumped back, sliding away from the crack to safety. I was surprised to see a Bahro link in at the Slate's position,

cracking the ice further with its weight. The Bahro placed one clawed hand upon the Slate, and both Bahro and Slate linked away, reappearing behind me in the shimmering bubble. The Bahro placed the Slate on the pedestal and linked away.

The Slates' "Magic"

The Slate itself is simple—a large piece of smoothed stone on which impressions can be drawn. And though heavy, the Slate is a convenient way to communicate with the Bahro. These impressions in the stone are obviously understood by the Bahro, but more than that, the Bahro will do what the symbols command. Also, if a Slate is placed out of reach for just a few moments, the Bahro act as a guardian and return the Slate safely to its resting place on the pedestal. From this we know that the Bahro are continuously watching the Slates, and they seem to feel that the Slate's place is on the pedestal.

From all we know of the Bahro, this could indicate that they are acting in a servile manner. If one could read their faces, we could perhaps discern whether they act with joy—or with bitterness.



The Bahro returned the dropped Slate to the pedestal.

I examined the crack in the ice. It was significantly wider now but still far too narrow for me to fit through. I attempted to cause it to crack further by stomping on it, to no avail. I wasn't heavy enough. But didn't Esher say something about being thankful for the heavy burden I carried...?



The Slate was heavy enough to crack the ice.

I picked up the Slate from the pedestal and walked over to the crack. Bowing to the additional weight of the Slate, the ice creaked, groaned and finally collapsed, dropping me into a narrow cavern several feet below the ice cave.

Second Pedestal

Exiting the cavern, I came to a wooden ladder leading up to the next plateau. I wasn't able to climb the ladder and hold the Slate at the same time, so I placed the Slate at the foot of the ladder and climbed up to find a second pedestal with a symbol inscribed upon it. Another symbol was inscribed on a nearby ice wall.



Two symbols...could they be inscribed on the Slate?



The second pedestal

I recalled Esher's instruction to command the Bahro by drawing their "elementary symbols" on the Slate. Making a quick sketch of the two symbols, I returned to the base of the ladder, only to find the Slate gone. I cursed myself for a fool for forgetting how the Bahro linked in to take the Slate after I dropped it in the ice cave. There was no way I would be able to climb back up to the link-in point through the crack in its floor. How was I going to get the Slate back?

I looked at the pedestal at the top of the ladder. In addition to the large glowing symbol inscribed inside of the outline of the Slate, there was also a smaller pentagonal symbol at its base. I touched the pentagonal symbol and found myself back inside the shimmering bubble at Tahgira's link-in point.

I took the Slate from the pedestal and carried it back to the base of the ladder. I knew I could not leave it behind without the Bahro taking it back to the first pedestal, so I decided to experiment with the two symbols I had seen at the top of the ladder. I inscribed the symbol from the second pedestal onto the Slate.

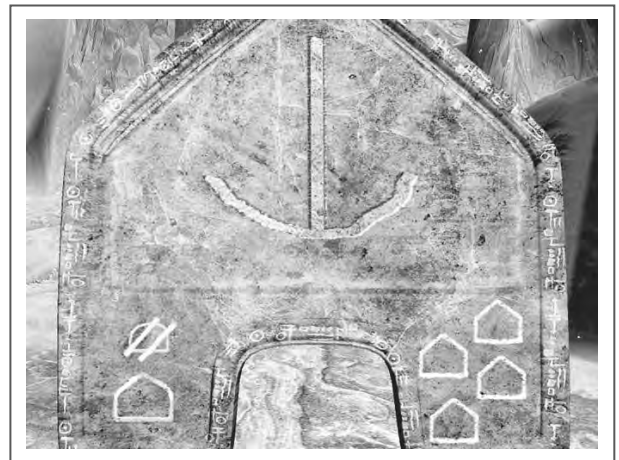

I inscribed the symbol from the second pedestal on the Slate.

Tahgira

Nothing happened. With the symbol still inscribed on the Slate, I set the Slate down and backed away from it. Just as before, a Bahro appeared and linked away with the Slate. However, instead of taking the Slate back to the first pedestal, it reappeared at the second pedestal and placed the Slate there.

Not only did that solve the problem of how to bring the Slate to the top of the ladder, it also taught me an important lesson about the Slate. If the Slate was inscribed with the symbol from a pedestal and placed on the ground, a Bahro would bring the Slate to the pedestal displaying the same symbol.

Note

I later found that each pedestal symbol I engraved onto the Slate also appeared on the base of the first pedestal, and that by touching any of the pedestal icons on the first pedestal, I could link to its respective pedestal.



The symbol inscribed on the Slate told the Bahro where to place it.

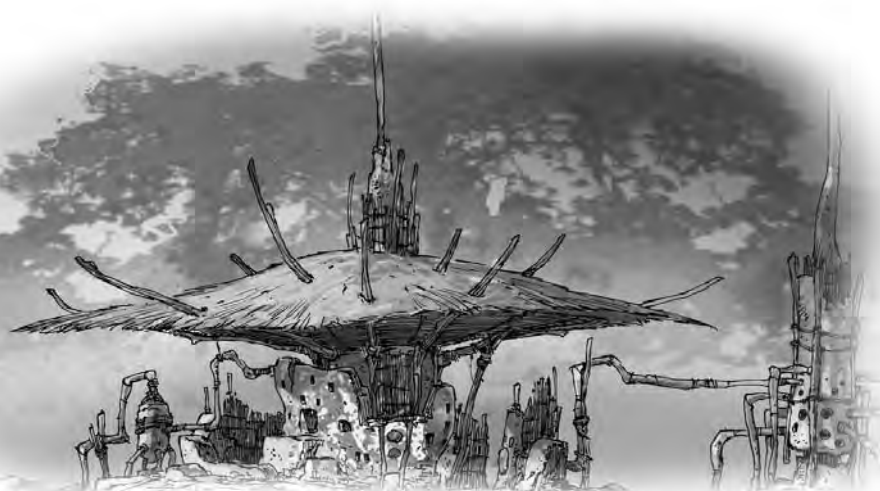

Turning Up the Heat



The symbol from the ice wall

Curious as to what the symbol on the ice wall indicated, I picked up the Slate from the second pedestal, wiped it clean, and inscribed it with the symbol from the ice wall. I laid the Slate on the icy ground and backed away from it.

Note

As I drew the next symbol, I noted that the symbol from the second pedestal now appeared in the Slate's lower right corner. Apparently the empty icons along the bottom of the Slate were used to record symbols that the Bahro understood.

Instead of taking the Slate away with it, the Bahro raised its hands. A blinding flash of light filled my entire field of vision. By the time I could see again, the Bahro was gone, the Slate was still on the ground and the temperature had risen noticeably.

Note

In further experiments with this symbol and the Slate, I found that if I did not pick up the Slate within 15 seconds of the "heat" power being activated, another Bahro would link in and return the Slate to the first pedestal, at the link-in point of the Age.

Tahgira

I picked up the Slate and started across a bridge that led across a vast chasm, but the other end of the bridge was blocked by a searing wall of steam shooting up from a wide crack in the ground. There was no way to pass it without severely scalding myself.



A wall of steam blocked the other end of the bridge.

I racked my brain to no avail for a solution to the problem, but, as it turned out, the problem solved itself. Approximately 90 seconds after the Bahro appeared and increased the geothermal temperature of the Age, the effect wore off. The wall of steam dissipated, and I was free to cross the bridge.

The Village

As I continued past the bridge, I came to a small village composed of crude steam engines that appeared to be harnessing the Age's geothermal energy as a heat source, judging from the melted ice around them. A tall hut sat in the center of the village, in the center of a grove of bulbous trees.

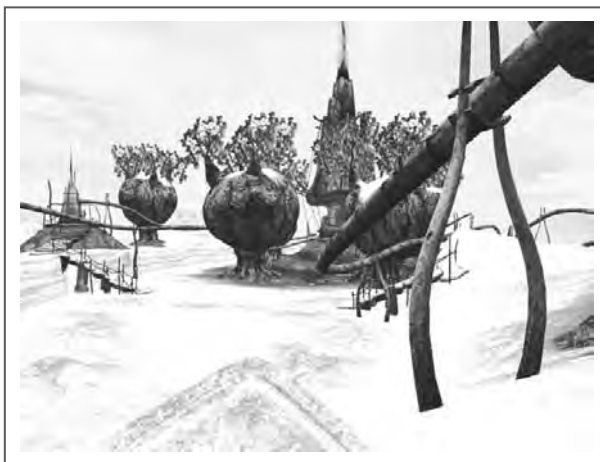

Several small structures, obviously generating heat

Frozen, Hostile Wasteland

Tahgira is a cold, inhospitable landscape without much warmth or comfort to offer a traveler. Perhaps this was the biggest reason the D'ni used it for one of their Prison Ages. This Age, however, was not a place where ordinary prisoners would be sent to "serve time"; rather, it was a place to which those convicted of the most monstrous crimes would be banished. There could be no return.

But instead of giving up and dying quickly, prisoners devised ways to tap natural steam resources of the land and built structures with which to harness and channel this power. Long after their excommunication from the D'ni society, the outlaws of D'ni were likely living in a Spartan but successful way. If there were ever a doubt the D'ni were a resourceful, inventive, and tenacious race, the prison Age of Tahgira would surely put those doubts to rest.

I approached the hut and found a third pedestal in front of it, with yet another symbol engraved on its surface. After making a sketch of the symbol, I drew it on the Slate and placed the Slate on the ground. After I backed away from the Slate, a Bahro linked in and placed the Slate on the third pedestal. I left the Slate on the pedestal, noting that the third pedestal's symbol now appeared in one of the Slate's previously empty icons, and proceeded into the hut.



The third pedestal

Esher greeted me at the entrance to the hut, where he delivered a short speech about his pride in the D'ni prisoners' ingenuity and his belief that D'ni would rise again (see sidebar).

Note

After I drew the third pedestal's symbol on the Slate, the symbol also appeared on the first pedestal's base, providing a direct link to the third pedestal.

Esher's Speech

Do you not marvel at what the prisoners were able to do here with so little? Structures, food, life...as D'ni built, so they did here.

Nothing. None of it matters now. The future is all we have. Justice is at hand. We will build again!

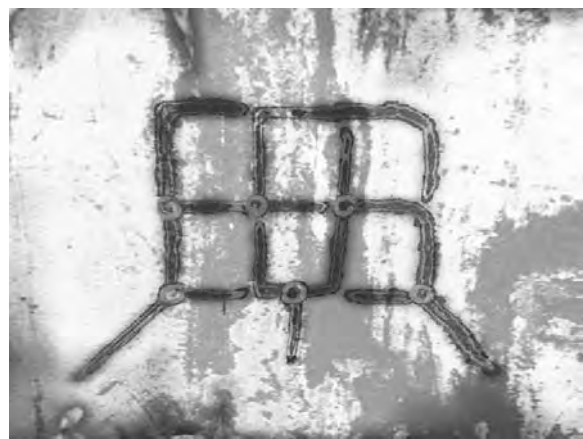

A map of some sort?

After Esher concluded his short speech, he linked away as usual, leaving me to explore the hut. The only item of note was something that appeared to be a map, hanging on the wall of the hut. The map was a 2x3 grid, with six circles at various intersections, three red and three blue. I made sure to photograph it before exiting the hut.

The Thermal Engines

I decided to investigate the village's six thermal engines next. Each had a switch on the front of it that presumably opened and closed the valve, but the switches were unlabeled, so I was unable to tell if the valves were open or closed.

As I approached the thermal engines to the right of the hut (as I faced the hut), Esher appeared again with another cryptic clue. He implied that there was more to the Age than met the eye, and that I should have the Bahro bring heat to it in order to continue (see sidebar).

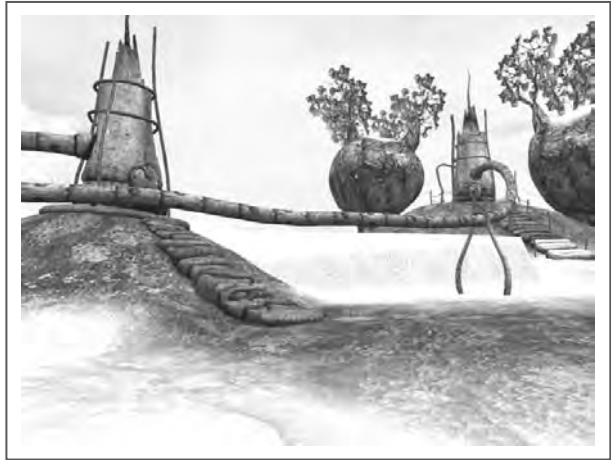

Two of the six thermal engines in the village

Esher's Speech

*I was not so sure of you.
And yet, you have done well.
But...do not be proud. You
think you understand what
you see...you may be wrong.*

*For example...this
appears to be ice, but there
is more. Like the prisoners,
there is life here that seeks
heat. Unseen life...in the
water.*

*There is no longer heat in
this place. But you can make
them bring it.*



Thermal junctions with nonfunctional control valves

Tahgira

I followed the piping from the thermal engines to a pair of junctions; three thermals led to each junction. Each junction also had what appeared to be a nonfunctional control panel made up of three switches, each of which looked as if they could be set to one of three positions...if they were operable, which they weren't. The control panel on one of the junctions was marked with blue buttons. The other was marked with red buttons. They seemed to have some connection to the three red and three blue circles on the map in the hut, but I didn't know what it was.

I followed the two large pipes leading out from the junctions to find a broad expanse of water with a grid of pipes running underneath it.

Referring back to my journal, I realized that the map in the hut matched the pipework in this water field. On the other side of the water field were some more structures, including what looked like another pedestal. Obviously, I needed to cross the water field, and from what Esher seemed to be telling me, I needed to harness the geothermal heat of the Age to do it...but how?



Water field

I decided that I had three mysteries to solve:

1. Figure out how to open the valves on the six thermal engines.
2. Find a way to access the three control switches on both thermal junctions.
3. Somehow create a path across the water field, presumably by using the thermals and the junctions.

Opening the Thermal Engine Valves



I drew the "heat" symbol on the Slate.



I turned the thermal switches to the right.

I picked up the Slate from the third pedestal, brought it over to the junctions and water field and touched the "heat" symbol in the Slate's lower left corner. The heat symbol drew itself, just as I had drawn it earlier. I placed it on the ground and backed away. Once again, a Bahro appeared and rose the geothermal temperature of the Age. The control switches in the junctions were still inoperable, and the water field remained unchanged, but a steam geyser now erupted in the distance beyond the water field.

As the heat effect faded, I contemplated the puzzle. There were three control switches on each junction, and each junction was fed by three thermal engines. Perhaps all of the thermals' valves were closed, which prevented the junctions' control switches from activating?

I knew it was a leap of logic, but from my studies of other D'ni devices, it didn't seem overly farfetched to me. I placed the Slate on the third pedestal near the hut so that I would have my hands free, and then I went to each thermal engine and turned its switch to the right.

Tahgira

Collecting the Slate from the third pillar, I returned to the junctions and used the heat symbol to increase the geothermal temperature of the Age. When my vision recovered from the brilliant flash of light, I saw that the three control switches on each junction were raised. As soon as the heat effect wore off, however, they recessed back into the junctions and were no longer operable.



Opening the thermal valves and triggering the heat effect raised the control switches on the junctions.

Creating a Path

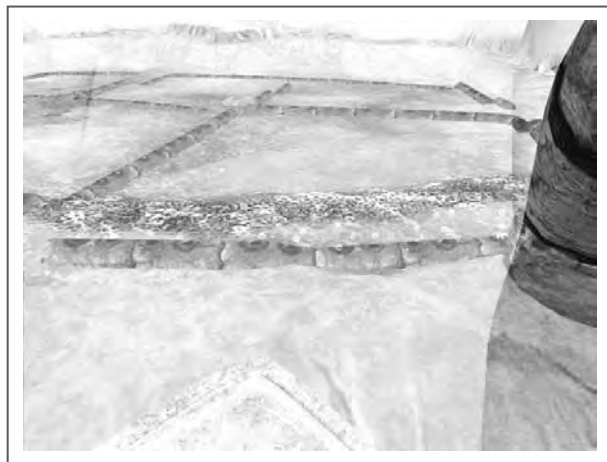

Directing heat into the water field created pathways of organic material.

I reactivated the heat effect and turned a few of the levers on the junction control panels. When I looked at the water field to see the effect, I was startled to see that coral-like pathways had appeared over certain lengths of pipe. Was this what Esher meant when he said that there is life here that seeks heat? Unseen life...in the water? From what I could tell, it seemed as if the heat from the pipes attracted millions of microscopic creatures, which I could walk across as long as they remained in position.

A Life Within

The micro-organisms in Tahgira are a truly fascinating and unique life form. They are attracted to heat. If they find a heat source, they collect together in large colonies, and then attach themselves to each other to form a solid mass. When the heat subsides, the organisms disconnect from each other and dissipate. However, if the heat source is extreme enough, the organisms will die while still locked together in their solid form. That solid form can then be used for other things, such as building materials.

The pool at the end of Tahgira was actually a farm the prisoners made for harvesting these organisms. They built the valve system so that they could create different shapes of solid material. The pool also had stair-steps so they could direct the heat to different areas to obtain different thicknesses of solid material.

After discovering that the intermediate form could be eaten (solid enough to handle, but not yet in its hardest state), the prisoners began to collect and use the organisms for food.

Thus, the organisms provided both a source of nutrition as well as a way to make various useful objects, turning the hostile world into one much more tolerable.

I now realized that the map in the hut was a guide that showed which junction's switches controlled which heating pipes in the water field. By setting the six switches correctly, I could form a pathway that would take me to the other side of the water field.

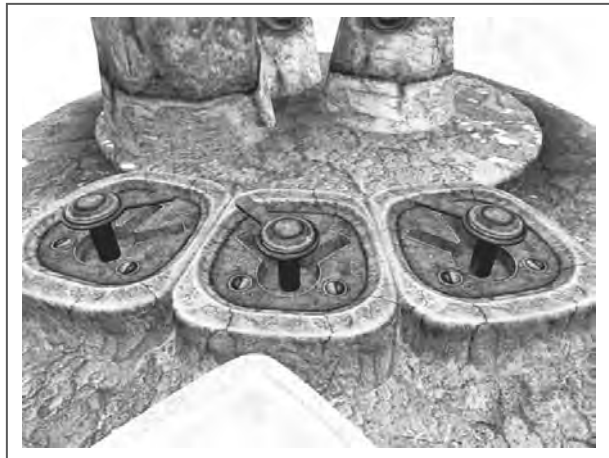

Right (blue) junction switches: right, left, left

Tahgira



Left (red) junction switches: left, right, left

After more trial and error than I care to recall, I finally discovered the solution to the puzzle. The blue junction switches (to the right of the water field as I faced it) needed to be set right, left, left. The red junction switches had to be set left, right, left.

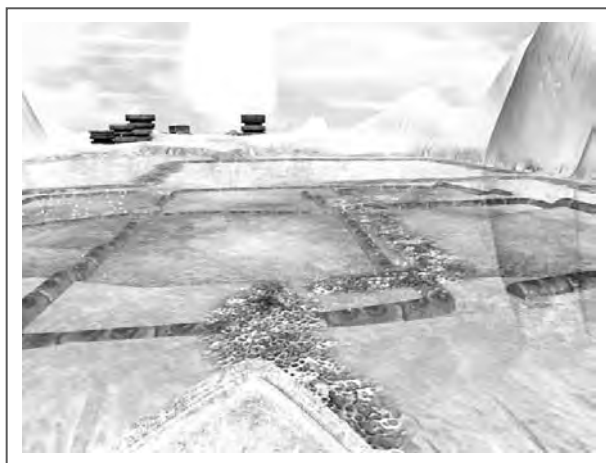

The pathway across the water field

Once the junction switches were in their proper positions and the heat effect was active, I carried the Slate carefully across the narrow pathway that led to the other side of the water field and into the area of Tahgira that I would come to call "the graveyard."

The Graveyard

As I entered the graveyard, Esher appeared. He indicated the tombs of the prisoners who had died in Tahgira and vowed that D'ni would rise again to build structures, not tombs. Indicating another shimmering bubble in the distance, which he called the "Keep," Esher told me to make the Bahro bring me to it, as it would "run" from me. (See sidebar for complete transcription.)



Esher told me that the Keep would "run" from me.

Esher's Speech

These are their tombs. And, as they died here, so did all of D'ni. Guilty here. But D'ni...was innocent. May we rebuild structures. Not leave tombs.

Make them bring you to the Keep...for it will run from you.



The fourth pedestal

The fourth pedestal in Tahgira stood in the graveyard. As before, I drew its symbol on the Slate and dropped the Slate so that the Bahro would return it to the fourth pedestal, with a new "shortcut" symbol at the bottom of it.

Note

The fourth pedestal's symbol also appeared on the first pedestal's base after I drew it on the Slate. I could now link from the first pedestal to the fourth pedestal directly.

Tahgira

Picking the Slate back up, I approached the shimmering bubble of the Keep, only to watch the ice floe on which it was built detach from the mainland and float away from me. Esher was right when he said it would "run" from me!

The "Keep"

The Keep is where the Tablet is housed in K'veer, and it is seen here at the end of our journey in Tahgira. Touching the Slate once it has been placed on the Keep is the last task in each Age. Once touched, the Keep begins to unlock the Tablet.

What started as amazement of the Bahro's abilities has now become awe and appreciation. The fact that the Keep is in K'veer and simultaneously here in Tahgira is a reminder that there is much to learn about the realities of the Bahro's worlds.



The Keep, with the fifth pedestal

However, I could see a fifth pedestal on the Keep, and its symbol was just barely visible to me. I drew it on the Slate as best I could and put the Slate down. The Bahro that came to collect it linked over to the Keep and placed the Slate on the pedestal.

Returning to the fourth pedestal, I touched the pentagonal symbol to return to the first pedestal, which now bore the Keep's symbol on it. Touching the Keep's symbol on the first pedestal linked me directly to the Keep.



I touched the Keep's symbol to link straight to it.

When I arrived at the Keep, Esher linked in and told me a little bit about it (see sidebar). He told me to touch the Slate to finish my task and then return to The Descent to D'ni, where I would find the Linking Book for the next Age.

Esher's Speech

Huh-hmmm... you have found the Keep, the destination for the Slates. You have seen this pedestal already in K'veer, where you started. And you will see it again. It is in... in many places at once.

Touch the Slate to finish your task. Only you can make them solid. Three remain.

Return to the tunnels, the path that leads to D'ni, and you will find another book.

Well done.

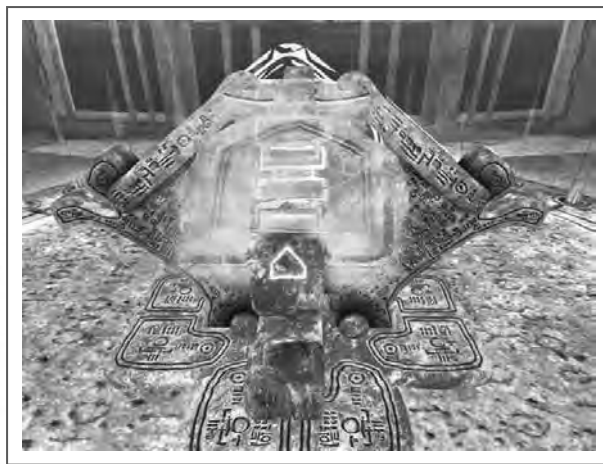

I touched the Slate to solidify it and complete the Tahgira portion of the Quest.

I did as Esher told me. I entered the bubble of the Keep, which showed an ethereal image of K'veer along its inner surface, and touched the translucent Slate. The Slate solidified, and one of the four stone locks that secured the Tablet was released.

Return to Direbo

Now it was time to return to the path to D'ni and find the Linking Book that would bring me to the next Age. To do so, I touched the pentagonal symbol on the Keep's pedestal to return to Tahgira's first pedestal. Touching the symbol in the center of the first pedestal's base brought me back to Direbo's Tahgira island. The Linking Book on the island linked back to the first rest area along The Descent to D'ni (Rest Area A).



Direbo's Tahgira island pedestal

Note

The pedestal on Direbo's Tahgira island was now illuminated with the symbols for all five of Tahgira's pedestals. Touching any of those symbols would take me directly to its corresponding pedestal.

I exited the rest area and turned right to proceed down the lava tunnel outside of it. It ended in a large round room, the center of which was dominated by a giant hub. As I approached the hub, Esher appeared and told me that he had taken the same Quest I was now on...and failed (see sidebar). He indicated one of the room's three doorways and told me that my journey continued on the other side of it.



Esher had failed the Quest I was now on.

Esher's Speech

I apologize for the goggles earlier, but my eyes are not accustomed to the sun in this Age.

I have taken this same journey...this same Quest...and failed. I'm not proud of my failure, yet I think that what I learned will be useful in your Quest.

(indicates door) Your journey continues through that door.

Before going through the door Esher had pointed to, I walked down the open doorway to the right of it and found another Yeesha Journal. It contained her thoughts on the **Riven** story and her ruminations on her divided nature (see sidebar).



Yeesha's third journal

Yeessa Journal III

*The stranger, the friend,
returned again to help
Father save Mother.
Imagine—a stranger—
traveling to Riven—risking
all, asking for nothing. I
think of humility, thinking
more of others.*

*Humility: prisoners are
freed by nothing more,
and nothing less.*

*Gehn, my grandfather, my heritage, ugh, that monster who thought
himself a god, was once again imprisoned. Perhaps he still rules that
desolate, empty, and dead place, riven by the pride and bitterness of his own
heart. But more likely he is in another desolate, empty, dead place, where
there is weeping. I hope he is miserable. I cannot forgive him for what he
did. It eats at my heart.*

I hate him, because I have his same desires.

*Mother and Father came again together to the refuge—to Myst Island.
But it was only a shell, a place to exist—a fallen place—torn apart by pride
just as the great D'ni city was.*

Just as I am. Torn.

*What is a stranger? Someone who is not me? Yet sometimes I feel like a
stranger to myself. I become two. One who I know, and one who I do not.
Where does this other one come from? Which one is me?*



In front of the door that Esher had gestured toward was a switch. I pulled it, and the massive machinery of the door lock groaned into motion, opening the door and revealing a large round tunnel beyond it.



The door and switch Esher indicated

I walked to the end of the tunnel, which opened into a vast vertical shaft. I recognized it from my studies as the Great Shaft of D'ni, an aborted attempt to reach earth's surface and create a conduit between humans and D'ni.



Walking counterclockwise around the balcony that overlooked the seemingly bottomless shaft, I again encountered Esher, who shared a rather biased interpretation of the fall of D'ni (see sidebar) before linking away again.

Esher blamed Yeesha's great-grandmother, Ti'ana, for the fall of D'ni.

Esher's Speech

Re goh-ro ti-wah...*The Great Shaft. Amazing, is it not? Built by those from beneath. My people. I am D'ni.*

It was this shaft that permitted the great-grandmother of Yeesha to find our deep city. Rather than bore you with tedious details, you need only know this: She killed us all, and the great D'ni city lies lifeless and ruined.

There is a room at the end of this first elevator. A small room with a D'ni Rest Age book for the D'ni who would have traveled this path. The book will link you to Direbo. I will come to you there.

Tahgira

Continuing counter-clockwise around the shaft, I came to the elevator that Esher mentioned. I pulled the lever to the left of it to summon it, and then stepped inside and pulled the overhead handle to send it down into the Great Shaft. I was relieved to see that, after hundreds of years and no maintenance, it still operated smoothly.



The topmost elevator of the Great Shaft

Rest Area B

After a descent of several minutes, I arrived at a lower landing. I could see the doorway to the rest area along the pathway leading clockwise from the elevator. A Bahro linked out as I entered.



Rest Area B

Another Yeesha journal sat on a bench along one side of the room. Opening it, I read of the many failed attempts to revive D'ni, failures that Yeesha felt as responsible for as anyone (see sidebar).



The fourth Yeesha journal

Yeesha Journal IV

I am sick of the Grower.

Oh yes, some believe in prophecies that predict the restoration of D'ni—the fallen city of D'ni would grow. There were attempts before, and there will be attempts again. But they always fail.

Even those led by my father tried. They learned great things of the Made and the Maker. They learned of the Bahro, of the Least, and of deeper truths. They learned of Father and his wisdom in rebuilding and rewriting.

The D'ni city came alive again, for a time. The dead were properly buried and the living were properly cared for. D'ni took short, labored breaths. Sap flowed, though the tree did not grow, for there was no grower.

Even Father did not see then as I do now.



Tahgira

The Grower had not come.

I had not come.

I am the Grower.

I failed.

And I think of myself as worthy? I am nothing—the failed child, of failed parents, of failed grandparents. How many generations must fail before we give up? Why do I try?

I have failed with the Tablet already. There are no second chances here. And yet I long to hold it, and try once more.

Return to Direbo

The only other item of note in the rest area was a Linking Book that led to another of Direbo's islands. I placed my hand upon its Linking Panel and returned to the rest Age. The island I appeared on was almost identical to the Tahgira island. I opened the two bridge gates on the island and stepped into the shimmering bubble that contained the pedestal link to the Age of Todelmer, the next step in my Quest. Laying my hand on the pedestal's glowing pentagonal icon, I linked to Todelmer.



Todelmer island pedestal

Todelmer

Pillar One

As in Tahgira, my link-in point for Todelmer was a translucent bubble with a pedestal in the center of it. The pedestal held a Slate, almost identical to the one I carried across Tahgira.

The "Takes"

There are four pedestals in Direbo. These pedestals are known as the "Takes" because these are the places from which you "take" the Slates. The views on the bubbles in which the Takes are housed are not mere projections; each Take is literally in two Ages at once—both in Direbo, and in the Age that corresponds to that Slate. When you are inside the bubble in Direbo, you can see the Age for that Slate, and when you are in that Age, you see Direbo through the bubble.

The Bahro, too, appear to be in two places at once as they link in and out, making me wonder if they are somehow related to the Takes.

Upon exiting the translucent bubble at Todelmer's link-in point, my heart leapt into my throat. I found myself on a narrow ledge, thousands of feet in the air, staring at a gargantuan ringed planet that filled the entire horizon of the night sky.



I wasn't prepared for this!

Todelmer

Looking out over the horizon, I saw dozens of other pillars protruding from the ground, similar to the one I linked onto. There was nothing to the right of the bubble as I left it, so I proceeded along a narrow pathway to the left of the bubble. The path wound around the pillar's circumference, leading me underneath elaborate pulley systems, and allowing me a view of complex mechanisms atop some of the adjacent pillars.



Complex pulleys and other mechanisms

Control Room

The pathway led me past a room full of colossal machinery lit with red light. As I approached, Esher linked in and told me that the Age of Todelmer was designed by the D'ni in order to study the heavens but was not finished before the fall of D'ni. He also repeated his assertion that Yeesha's great-grandmother, Ti'ana, was responsible for the destruction of D'ni. (See sidebar for complete transcription.)



Esher blamed D'ni's collapse on Yeesha's great-grandmother.

Esher's Speech

Todelmer, built to study the heavens—and glorious heavens you will find here. I'm only sad we were never allowed to finish.

I have told you some of the story...Yeesha's great-grandmother Ti'ana came to us desperate for control, convincing our people to betray rules we had held for generations. And we died.

Yeesha claims such death, as painful as it was, had to be done—a plan of the Maker...and that she will rebuild. She will rebuild. I will tell you such delusive wisdom comes from vague feelings and daydreams—and the Tablet you will have is far too powerful for such wisdom.

Todelmer. Enjoy the beauty of the heavens, while you consider the power that can control them.

After Esher linked out, I took the opportunity to examine the room. Four massive pulleys at the front of it led up to the roof. I surmised that they were probably somehow connected to the pulley systems outside of the pillar. On the raised dais in the middle of the room sat four mushroom-shaped devices that appeared to be control panels of some description. I assumed that, because there were four pulleys and four control panels, it was likely that the control panels were used to activate the pulleys—and whatever the pulleys were attached to. However, I was unable to test my hypothesis, as there was no power flowing to the control panels.



Four control panels for the four pulleys?

Todelmer

At the rear of the dais was a tall vertical mechanism lined with D'ni numbers. An arm attached to a large gear sat at the top of the mechanism. It looked as if it was used to measure something, but there was no way to tell what exactly.

I stepped off of the dais and walked around the inner perimeter of the room to reach the rear of it, where I found a dim blue globe and two switches, one horizontal and one vertical. I found that, by moving the switches, I could cause the globe to brighten or dim.

The red light in the control room was so dim that I decided to try to use the globe to brighten the room up a bit. The globe glowed brightest when the left lever was set at its middle position and the right lever was pushed all the way to the right. And not only did this cause the globe to light up considerably, it also restored power to the control room!

I walked back around to the front of the room, where the four control panels and the measuring device hummed with life. The measuring device moved with such deliberate regularity that I guessed it must have been a clock or other timekeeping device.

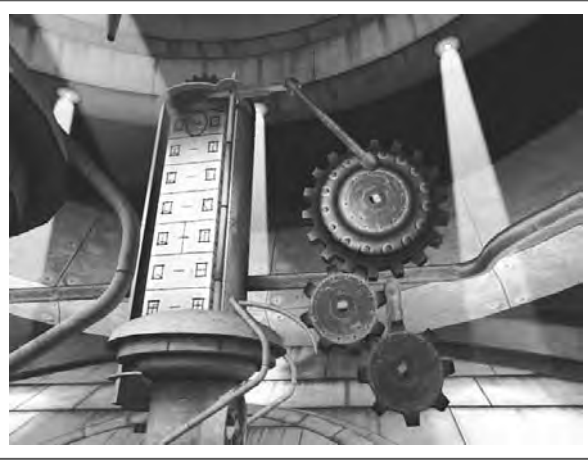

Some sort of measuring device?

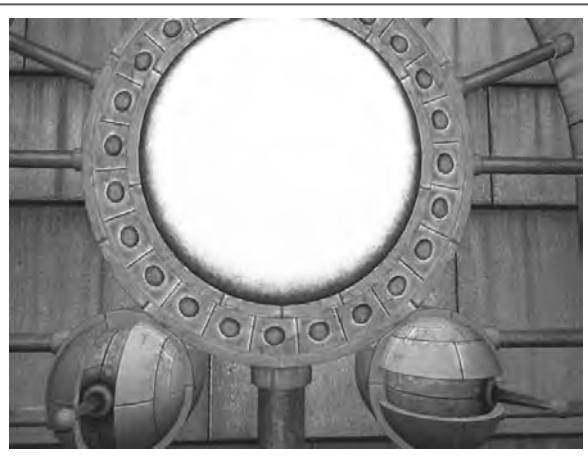

Power was restored when the left switch was set halfway and the right switch was moved all the way to the right.

Removing an Obstacle

Not wanting to touch the control panels until I knew what I was doing, I left the control room and continued my exploration of the first pillar. As I continued moving counterclockwise around the pillar, I followed the cables from the control room's pulley system. They appeared to connect to large mechanisms that pointed up at the sky on other pillars. From their shape and positioning, and from what Esher had told me about Todelmer, I surmised that the mechanisms were probably telescopes.

The Final Frontier

The D'ni were space travelers, but not in the way we earthlings imagine "aliens" get around. Rather than build and board crafts to fly thousands of light years between worlds, the people of Garternay, the ancient ancestors of the D'ni, created a far more elegant and immediate form of travel: Linking Books. These Linking Books were used to transport living tissue directly onto new worlds. And yet, that did not deter the D'ni from examining and learning all they could about the vast space between these worlds.

Todelmer is a perfect example of the D'ni pursuit of knowledge of the universe around them. Vast and intricate machines, complex inventions, and many experiments can be found wherever the D'ni had traveled. Todelmer houses just such machines and inventions. This Age, built solely for the study and exploration of the heavens, is a perfect example of the beauty and awe the D'ni both sought and inspired.

I kept climbing up the pillar, only to find my path blocked by a massive coil of cable from a ruined pulley. It was far too heavy for me to lift out of the way, and I wasn't about to risk falling off of the narrow ledge by attempting to climb over it. If the mechanisms in the control room did in fact control the pulleys, I reasoned that I should be able to move the cable out of the way from there.

Todelmer



Path blocked by broken pulley cable

I returned to the control room and examined the four control panels. Three of them displayed views of the starry night sky on round monitors. The fourth showed only static. I assumed that this control panel probably corresponded to the broken pulley.

I noticed horizontal and vertical sliders in the upper left corner of the control panels. These seemed to control the horizontal and vertical orientation of the

telescope—or would control, if this one wasn't broken. Horizontal and vertical coordinates were displayed (in D'ni numerals) in small round windows below the sliders. Between the sliders and the windows was a map of the sky, with one quarter of it highlighted.

Now all I had to do was figure out which direction to move the sliders in order to reel in the broken pulley cable on the path outside. After a bit of trial and error, I discovered that elevating a telescope pulled its cable back toward the control room, so I moved the vertical slider all the way up and touched the flashing green button in the center of the control panel to activate the mechanism. When I returned to the blocked pathway, I found the cable had retracted far enough to allow me to pass safely.

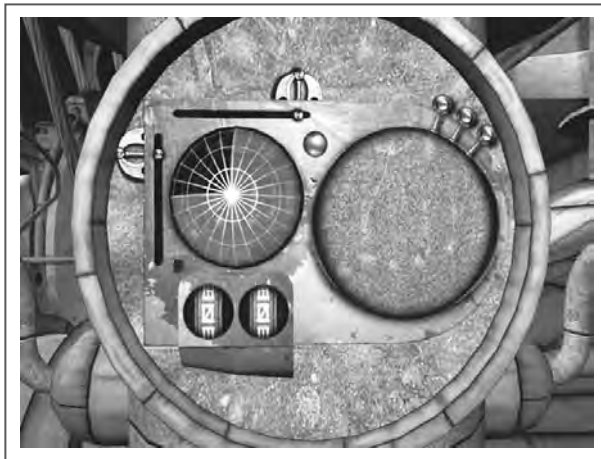

I used the rear right control panel to raise the broken cable.

Mini-Telescope

After a climb that left me winded, I reached the top of the first pillar. To the right of the top of the stairs was a smaller version of the devices I'd seen on top of other pillars. Examining this device revealed it to be a telescope, which helped confirm my hypothesis that the larger mechanisms on the other pillars were also telescopes.



Mini-telescope on top of the first pillar

I looked through the lens of the telescope to see what I could make out of the other pillars. A vertical slider to the left of the lens controlled the vertical pan, a slider below and to the right of the lens controlled the horizontal pan, and a third slider above and to the right of the lens controlled the zoom.

I started by zooming in on the pillar that the telescope was already pointed at. As I did, I saw a cable tram parked at a dock on the distant pillar, as well as three glowing symbols etched into the pillar below the dock. The second two were D'ni numerals; I didn't recognize the first, which looked like three-quarters of a circle. I made a note of the symbols.



Three symbols etched below the tram dock

I left the telescope and looked out over the Age from the edge of the top of the first pillar. I saw how the pulleys from the control room connected to the large telescopes on other pillars. I also saw a second set of cables for the tram stretching between the pillar I was on and two other pillars. On a

Todelmer

whim, I returned to the telescope and tried looking through it again to see the tops of all of the lighted pillars in my field of view, but a large spool for the tram cable obscured my view of one of the towers. Perhaps if I could move that spool, I'd be able to see what was up there...?



A spool blocked my view of another tower.

Tram House

I entered the small tram house on top of the first pillar and examined a map on the rear wall. It seemed to be an illustration of the pillars in the vicinity. Four red circles seemed to represent the four telescopes, while the large blue circle in the middle of the map indicated my present position on the first pillar. A green line led from the first pillar to a second pillar (presumably the tram line), and a third pillar sat off in the distance.

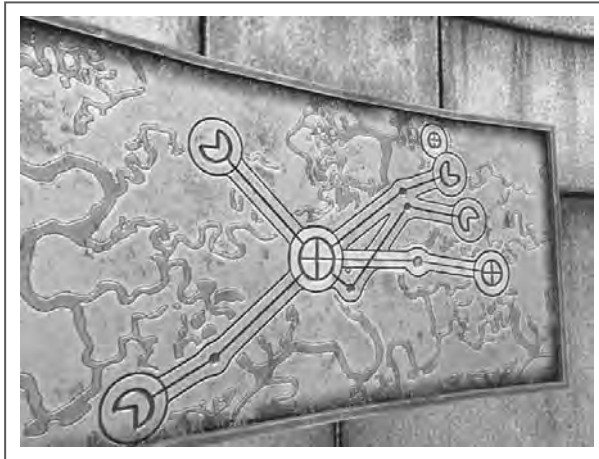

Tram house map

I recognized the symbol I had just seen through the mini-telescope as the symbol for one of the four large telescopes, as indicated on the map. Thinking back to the control panels in the control room, I remembered that each displayed a view of the night sky, with one quarter of it highlighted. I was willing to bet that each of the four telescopes was set up to view a different quadrant of the sky. Did this mean that the three symbols I saw

through the mini-telescope were coordinates for one of the four large telescopes? I made a mental note to test the theory later.

Returning to the tram room door, I pressed a dull silver button in the center of it to close it from the inside of the room. It slid shut to reveal another button behind it, which I also pressed. This caused a hidden set of stairs to appear near the map at the rear of the room.

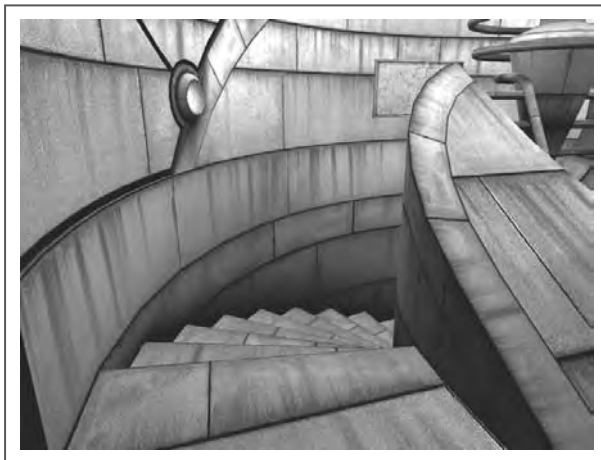

Hidden stairs

The stairs led down to the tram dock. The tram was not present. Standing at the edge of the dock and looking up, I saw that the large cable spool that had blocked my view through the mini-telescope was directly overhead. This reminded me that I was going to try to move the spool and view the obscured pillar.

There were only two controls for the tram. A bit of trial and error revealed that the top lever, which moved left and right, determined the tram's direction. The lower lever, which moved up and down, turned the large spool overhead and moved the tram. Because I wasn't trying to access the tram just yet, I left the top lever in its rightmost position and pulled the middle lever once to rotate the cable spool.

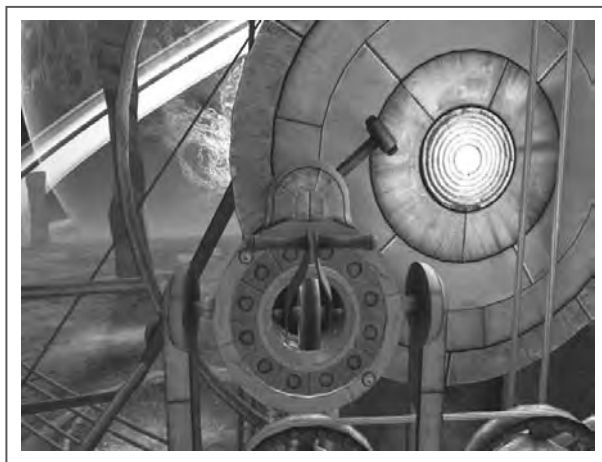

Tram controls—I left the top lever alone and pulled the middle one once.

The Second Pedestal

Returning to the mini-telescope, I looked through it at the now-revealed pillar top, and I was very glad I had followed my hunch. Sitting atop the pillar was the second pedestal for the Age, with its symbol in plain view. I confess that I had almost forgotten about the Slate and its power, but this was my chance to see if Todelmer's Slate functioned in the same manner as Tahgira's.

Symbolism

The symbols we use to communicate with the Bahro are rudimentary yet highly effective. What appears to be a simple set of lines or circles actually represents something very significant, and most of the time each symbol will bring an important accompanying action with it.

Learning a new language brings back memories of other languages we have had to learn to travel throughout the worlds of Myst: D'ni, Narayani, Serenian. Now, learning that we not only can communicate with the Bahro but that they also have their own complex language reminds us again just how little is understood of these quiet, servile beings.

Symbols have been found throughout the Ages, and it is one of the explorer's most enjoyable and intriguing jobs to discern and translate such symbols. With the Bahro language, a new challenge is presenting itself.

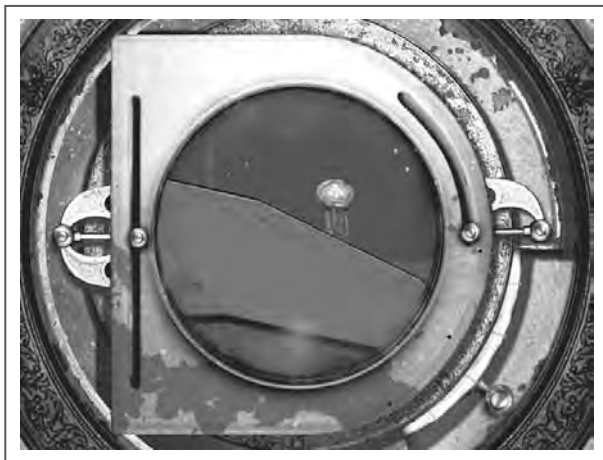

The second pedestal

I returned to the first pedestal at Todelmer's link-in point and picked up the Slate. Tracing the symbol for the second pedestal on its surface, I laid it down and backed away. Sure enough, a Bahro came to claim it, linking away with the Slate. I returned to the first pedestal and saw that the symbol for the second pedestal now glowed on its

base. I touched the symbol to link to the second pedestal, located on top of the second pillar I would visit in this Age.



The second pedestal's symbol appeared on the first pedestal.

Pillar Two

From the second pedestal atop the second pillar, I turned around and saw the first pillar in the distance. I stepped behind another small telescope located on the second pillar and looked back at the first pillar. As I panned down to look at the tram dock, I saw another set of three glowing symbols engraved below it. Once again, they seemed to be a quadrant symbol, followed by two D'ni numerals. I made sure to copy them into my journal before proceeding.

After finding two sets of coordinates on two pillars' tram docks, I surmised that there must be a third set on the third pillar's dock. However, when I turned the second pillar's mini-telescope in the direction of the third pillar, I found my view obscured by two of the four large telescopes. I would have to move them to get a good



Three more symbols below the first pillar's tram dock

Todelmer

view of the third pillar's tram dock. It seemed like a good time to enter the two sets of coordinates that I'd already found into the control panels back on the first pillar's control room.

I touched the pentagonal symbol on the second pedestal to link back to the first pedestal. From there, I returned to the control room. The first symbol in each set of coordinates indicated the telescope that it corresponded to. The first coordinates I found (via the first pillar's mini-telescope) were for the front right control panel. The second coordinates were for the front left control panel.



The view of the third pillar, obscured by telescopes

Note

Following the pulley system confirmed that these control panels did indeed control the two telescopes that were blocking my view of the third pillar's tram dock from the second pillar's mini-telescope.

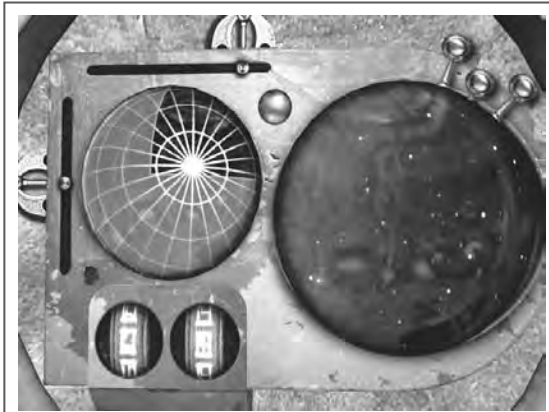

Proper positioning for the first coordinates—front right control panel

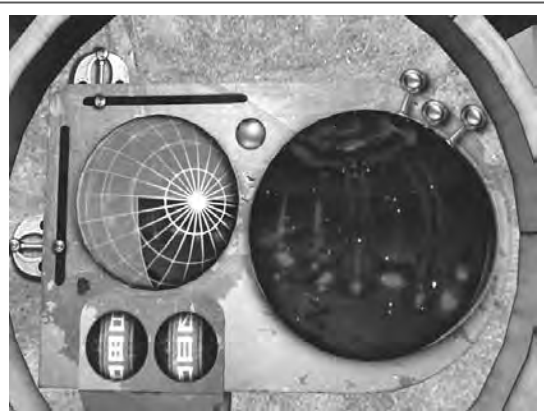

Proper positioning for the second coordinates—front left control panel

I entered the coordinates on each control panel and pressed the flashing green button on each panel to activate the telescopes. Returning to the first pedestal, I linked to the second pedestal and looked through its mini-telescope to get a slightly less obstructed view of the third pillar. I zoomed the telescope through the eye of one of the large telescopes' brackets...and saw the third pedestal!

I picked up the Slate and drew the third pedestal's symbol on it, laid the Slate on the ground and backed away. A Bahro appeared and linked with the Slate to the third pedestal. I used the second pedestal to link back to the first pedestal. From there, I touched the third pedestal's icon to link to the third pedestal on top of the third pillar.



The third pedestal

Pillar Three

The third pillar was similar to the first pillar. As I explored the top of it, Esher linked in to tell me that my destination was "above," and that I would have to use the Bahro's power to align the stars and planets (see sidebar). I had no idea what he could mean, so I decided to thoroughly explore the third pillar for clues.



Esher told me that the "stars and planets must be aligned."

Esher's Speech

Your destination is not here, but above. The stars and planets must be aligned, and regrettably it is only the perverted power of the creatures that can do it.

Make them.

Esher

Esher is an enigma. He is D'ni, born in the great underground city, and was only a child when D'ni fell. He seems to want to help us and guide us through each Age, teaching us of the past and alerting us to the present; he seems almost grandfatherly in his concern, and he has wisdom about many things; and he seems to scoff at Yeesha's dream of rebuilding D'ni and chide us for wanting or seeking any power of our own. But what is he hiding? Could it be that he is the Grower of which the prophecy speaks? Or is his drive to help one of a misguided Messiah complex? Are his actions merely contrived to gain our trust to further his own end?

My first instinct was to try to open the tram house door, but I found it securely locked. Descending the stairs next to the third pedestal, I came to the tram dock, but the tram was just slightly too far from the dock for me to enter—the result of me moving it earlier so that I could see the second pedestal from the first pillar's mini-telescope.



*The tram was not properly docked;
I couldn't get in it.*

Docking the Tram

Using the third pedestal's link, I returned to the first pillar and made the long hike back to the first pillar's tram dock. This time, in order to return the tram to the dock on the third pillar, I moved the top lever to the left (to reverse the tram's direction) and pulled the bottom lever once (to move the tram back into the third pillar dock).

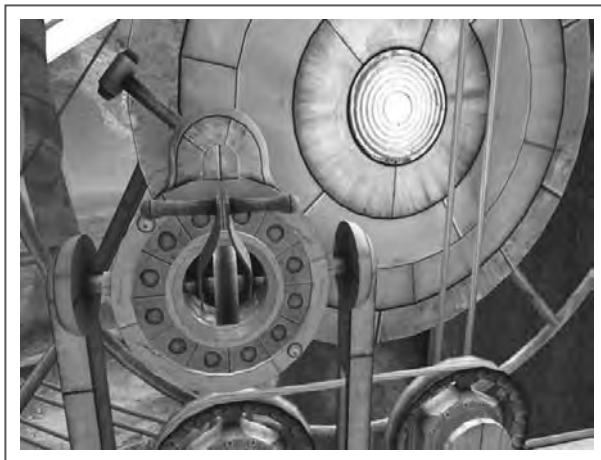

To park the tram in the third pillar dock, I moved the top handle to the left and pulled the bottom one once.

I returned to the first pedestal and linked from it to the third pedestal. Descending the stairs near the pedestal, I found that the tram was now securely docked. I walked out onto the top of it and climbed down a ladder into it.



The tram, securely docked at the third pillar

Tram House

Pulling the lever in the middle of the tram had no effect. It seemed as if the tram still needed power. I walked through the tram to reach the stairs leading up to the locked tram house. On the way up, I encountered another power control panel, similar to the one at the rear of the control room in the first pillar. To restore power to the third pillar, I set the right lever to its middle position and moved the left lever about two-thirds of the way up.

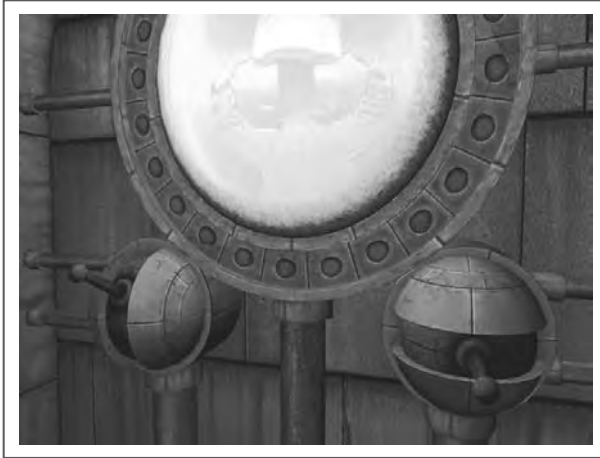

I restored power by moving the levers to these positions.

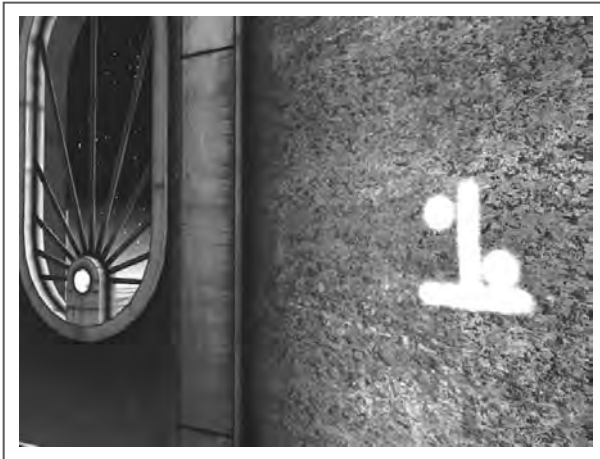

Symbol on the inside wall of the third pillar tram house

With the power restored to the third pillar, I continued climbing the stairs up to the tram house. At the doorway at the top of the stairs, I pressed a button to lower the hidden staircase inside of the tram house, and then I climbed the stairs.

On the wall inside the third pillar's tram house, I saw a glowing symbol etched into the wall. Because I didn't find it on a pillar, I assumed it must be a special Bahro ability, similar to the heat symbol in Tahgira. I copied it into my journal and made a mental note to experiment with it later.

I opened the tram house door for easier future access, and then I descended the stairs to the tram. It was time to go for a ride.

Operating the Tram

The tram controls were extremely simple. A single lever in the middle of it served as the throttle. When it was pushed forward, the tram would move forward. When it was pulled back, the tram would move backward. I stepped into the tram and pushed the lever forward to start moving toward the first pillar.

Halfway to the first pillar, the tram creaked to a stop. Panic started to take hold—if I couldn't get the tram moving, my only way of returning to a pillar would be to climb along the tram cables! Fortunately, four symbols etched onto some machinery directly outside of the tram distracted me from my fear. The first was the image of a ringed planet, with its ring tipped at an angle between 100 and 120 degrees. The other three were a third set of coordinates for the third operable control panel in the first pillar's control room!

I copied the symbols into my journal with a shaking hand and, with a prayer on my lips, pulled the tram handle again. I breathed a sigh of relief as the tram creaked into motion and completed its journey to the first pillar.

As soon as the tram docked, I exited it and climbed the stairs into the first pillar's tram house. From there, I returned to the control room and entered the third set of coordinates into the only control panel I had not used (the rear left one).

I stepped outside, expecting that something would have happened, but nothing in the Age seemed to have changed. I was left with three mysteries:



Four symbols etched halfway between the first and third pillars

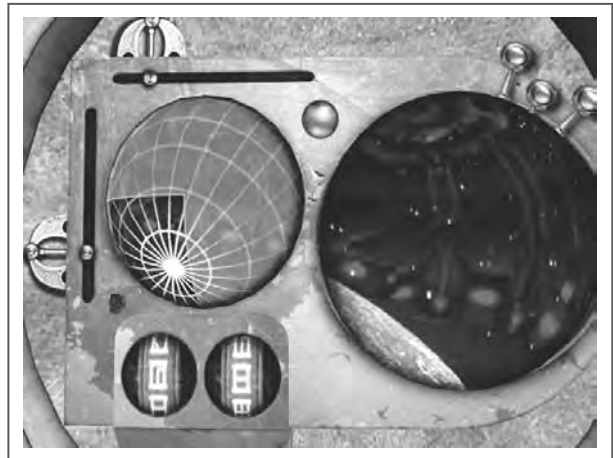

Proper positioning for the third set of coordinates in the rear left control panel

1. What did Esher mean when he said that I needed to use the Bahro's power to align the stars and planets?
2. What did the symbol etched on the inside of the third pillar's tram house mean?
3. What was the significance of the planet symbol I saw on the tram ride?

Advance Seasons

I decided to start with the most obvious mystery and find out what effect the mystery Bahro symbol would produce. Returning to the first pedestal, I linked back to the third pedestal and picked up the Slate. After drawing the symbol upon it, I placed it on the ground and backed away, triggering the appearance of a Bahro.



The mystery symbol

The Bahro looked at the Slate and raised its arms. A blinding flash of light filled the Age. I can scarcely explain what happened next. At first, I thought it was just that the wind had started blowing harder, but it was more than that. The stars in the heavens shifted noticeably. The clouds whipped along the surface of the planet in a frenzy. As

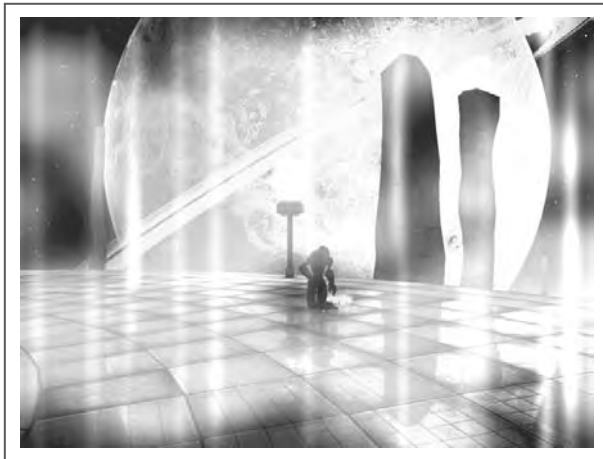

The symbol caused the Bahro to speed up time!

impossible as it seemed, the Bahro had sped up time!

The effect wore off in what was 90 seconds for me subjectively, but days, months...maybe even years had passed in the Age. Even the ring of the planet overhead had tilted.

The planet's ring! That was what the planet symbol indicated! For me to complete my Quest, I needed to be at a point where the ring of the planet overhead was at the same angle as the one in the symbol.

I used the "time" symbol again to speed up the flow of time in the Age. When the effect ended, the angle of the planet's ring matched the one on the symbol I had seen earlier. Now what?

Note

As with the heat symbol in Tahgira, I had approximately 15 seconds to pick up the Slate again before the Bahro came back for it and returned it to the first pedestal.

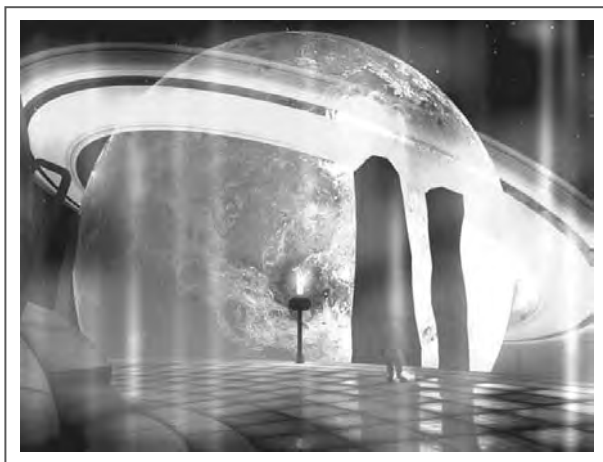

The planet's ring rotated as time sped by.

The Space Pod

I had seen the planet symbol on top of the third set of telescope coordinates. Was that a clue? I had nothing better to go on, so I returned to the control room with the Slate and looked at the rear left control panel's monitor. A small light blinked at the edge of the planet's ring, too bright and regular to be a star or other natural object.

Three buttons above the monitor controlled the zoom for the telescope. Pressing the third one zoomed in on the blinking object and revealed the fourth pedestal, clear as day!

Todelmer

I backed away from the monitor in shock. If I understood what I was seeing properly, the fourth pedestal wasn't even on the same planet I linked into! Was I truly prepared to make this leap of faith?

My hands shook as I inscribed the symbol onto the Slate. I had come too far to stop now. When the Bahro linked away with the Slate, I nervously approached the first pedestal and waited for the fourth pedestal's symbol to appear. As soon as it did, I touched it before I could talk myself out of it.

I linked into a space pod, orbiting high above the blue-ringed planet. Esher was there, waiting for me. He told me that it was only through the power of the Tablet that such a miracle like this was possible. He again warned me against giving the Tablet to Yeesha, saying that she had destroyed the D'ni once (see sidebar).



The fourth pedestal



Esher warns of Yeesha's destructive power, should she get her hands on the Tablet.

Esher's Speech

Do you begin to understand the power of the Tablet? Surely it begins to pull you...its strength grips you. Look around—without the power of the Tablet—this would be left solely to your dreams. Now, imagine how the power calls her. She has tasted it already, she has the ability to use it beyond all others, and she tells you not to give it to her, because she wants it so.

She destroyed the D'ni once, and she will complete our destruction if you give her the Tablet.

Listen carefully. The quest is half complete and the decision nears. You have seen much...of what the D'ni once were, what they were able to build. Do you see what we might create yet again? The city, the Ages. Do you see it? Go, bring us closer.

I descended the ladder to find the Keep under the landing I linked onto. Before entering the Keep, I looked out of the windows of the space pod at the wonders outside. It was a view most people would never experience—the frozen asteroids that composed the ring of a planet, seen from an impossibly close range. If this was evidence of the power of the Tablet, of the Bahro, could I trust Yeesha or Esher with it?

For that matter, could I trust myself?

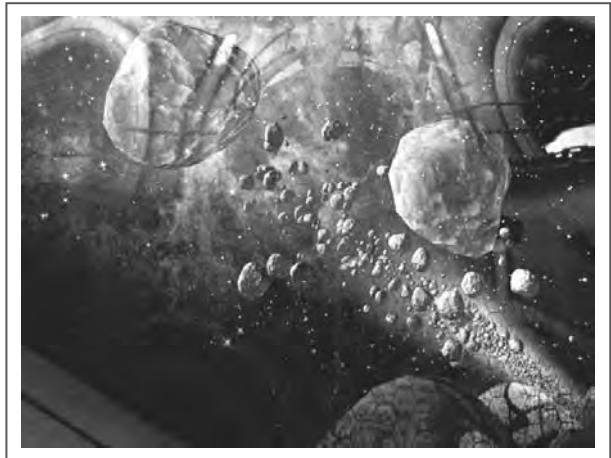

The miraculous view from the space pod

Todelmer

These thoughts weighed heavily on my mind as I entered the Keep and touched the Todelmer Slate to release the second of the four Tablet locks. With the lock released, I touched the pentagonal symbol below it to return to the first pedestal, and then the Direbo symbol on the first pedestal to return to the rest Age.



Return to Direbo

I used the Linking Book on Direbo's Todelmer island to return to the last D'ni rest area I had visited (Rest Area B). From there, I exited the rest area and turned left, following the Great Shaft pathway in a clockwise direction. I came to another elevator, with another Yeesha journal next to its call lever (see sidebar). After reading the journal, I called the elevator and rode it down even deeper into the Great Shaft.



The fifth Yeesha journal, next to the second elevator's call lever

Yeesha Journal V

Tomahna—my home—the place where I was: the place where I began. I was a spark of joy to Mother and Father, after their fire was almost quenched. And yet what joy could we have had if my brothers had been there as well?

Still torn.

Father and Mother loved and shared with me, their desert bird. Father shared wisdom and knowledge, and Mother shared visions and dreams.

When did they come to know my destiny? Surely not from birth. As I look back, they knew so much; they saw so clearly. They planted and watered, so that I would learn how to do the same. I would not realize it until long after I was to see them no longer.

Am I the Grower because they taught me, or did they teach me because I am the Grower?

Torn.

But peace was not yet with us. From the past, an enemy came, seeking revenge. But there was help for a third time. Without help, where would we be? Would there be a Grower? Would there be a seed to grow?

It's all been so fragile.

But it must be by the Maker I am here—and there is meaning.

Or it may be by the roll I am here—and there is no meaning.



I exited the elevator and proceeded down red-carpeted stairs leading away from it. Esher linked in and met me at the bottom of them, telling me that we were three miles below the surface, and that if I wanted to proceed any farther, I would have to raise the floor of the Great Shaft and power the exhaust fans to provide air to the tunnels below. (See sidebar for a complete transcription.)

From my present position, I could see four balconies that extended toward the shaft's center. An open doorway yawned behind me. I saw another on the opposite side of the shaft, but there was no way to reach it.

Each of the four balconies had a threaded column beneath it, reminiscent of massive screws. I assumed that these were the guides for the elevating floor that Esher spoke of...but how to raise it?

Esher's Speech

Stand in awe. The surface is three miles above us. Three miles. Our construction was triumphant and tragic.

You will not be able to continue downward without providing fresh air to the tunnels. Raise this floor and power the fans. I trust you can discover how.



Esher told me to raise the floor of the Great Shaft.

Raising the Floor

I walked down the stairs beyond the doorway behind me and kept descending, bearing right at every turn (and startling a Bahro or two along the way). Eventually, I came to a glowing blue switch with a Yeesha journal next to it (see sidebar). I picked up the journal but left the switch alone for the moment.



Yeesha journal and a blue switch

Yeesha Journal VI

I was very young when I first felt strong. Indeed, I was young, but I thought I understood. I had many abilities, even then, but little wisdom. Better to have fewer abilities and much wisdom.

I knew I was doing something great for us, but what I did was foolish for me. I thought I was reuniting our family, bringing back what joy we once had. I almost brought an end to life.

Yet again, it was a friend who came to our aid.

Now I think that most things cannot be returned to how they were. My brothers were not to be released. But the Maker turned my poor choice to some small good, and Achenar was redeemed.



Todelmer

My tears flow as I write these memories. The suffering and pain I have caused—and endured. And yet I am thankful. I will be powerful like the Bahro.

I long to be so strong.

They will sing a song of thankfulness. They will sing a song, without regard to their circumstances. They will stand and take time to sing to the Maker with hearts of joy. If only I could have such a heart.

I continued down the stairs until I reached the floor of the Great Shaft itself. I had never known the definition of the word "awestruck" until that moment. This was the gateway between the surface world and the deep city itself, which I had read so much about in Atrus' journals and the journals of other D'ni explorers. And this was the floor that I would have to raise if I was to proceed. A giant stone button protruded from its center, but pressing it did nothing.

I crossed the floor and entered a doorway directly across the shaft from the one I had just come through. The stairs on the other side of it led to a yellow switch, identical to the blue one I had just seen.



A yellow switch on the opposite side of the shaft

This time, I pressed the switch. A timing mechanism activated and started counting down slowly. I ran back down the stairs and across the floor of the Great Shaft once again. The button in the center of the floor now glowed yellow.

I returned to the blue switch and pressed it. A second timing mechanism began counting down. Returning to the center of the floor of

the Great Shaft, I saw that the button was now red. I pressed it.

For a few seconds, nothing happened. And then colossal ancient mechanisms slowly groaned into life for the first time in who knows how many years. The floor began to rise, carrying me with it.

The floor came to a halt at the four balconies at the level of the second elevator. I was now able to reach the previously inaccessible doorway, and I found a Yeesha journal and a switch. I read the journal (see sidebar) and pulled the switch to the left to start what sounded like a generator or turbine. It was a fairly safe bet that this powered the fans Esher had spoken of earlier.



The button glowed red when both switches were activated before the timers counted down.



Yeesha journal and generator switch

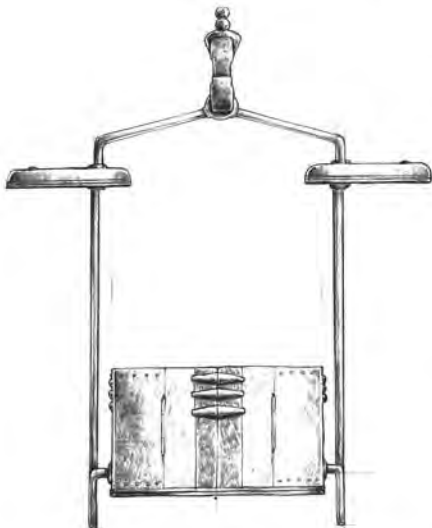

Yeesha Journal VII

Alone.

There is a powerful conjunction between the in and the out, the beneath and the above. A wound, a mouth, a well, a pit. I wanted to make the journey for myself from where the D'ni dug upward, where they almost came to the surface. From the place where Ti'ana first climbed downward, and where Father followed evil into the ground.



I began my journey with a heavy burden. It was Ti'ana who came to D'ni, and caused its fall. I am from her. I feel I am destined to bring another destruction.

Father and Mother tried to prepare me—tried to tell me who they thought I was. I still see the power of each. I have the best of each—and the burden of each. And as they watched me leave, I saw the sadness and the fear. But more terrifying, I saw their hope.

And I left my comfort to find me. And even as I took my first step away from Tomahna, my shoulders ached, for the burden I bore. Deep prophecies and weighty destinies.

So much to learn and understand about myself. My father said we can never understand—we can only understand more.

The more I understood the more I powerful I became, and the more dangerous I became, and the less I understood.

Rest Area C

To the left of the generator switch was another D'ni rest area, the third I had discovered on my descent to D'ni. There was nothing in the rest area of immediate importance except a Linking Book to Direbo. I placed my hand on the Linking Panel and linked.

As in my previous two visits to Direbo, my first action was to unlock the two bridge gates on the island. This gave me direct access to the Tahgira island. With that done, I stepped into the shimmering bubble and placed my hand on the glowing blue symbol on the pedestal to link to the Age of Noloben.

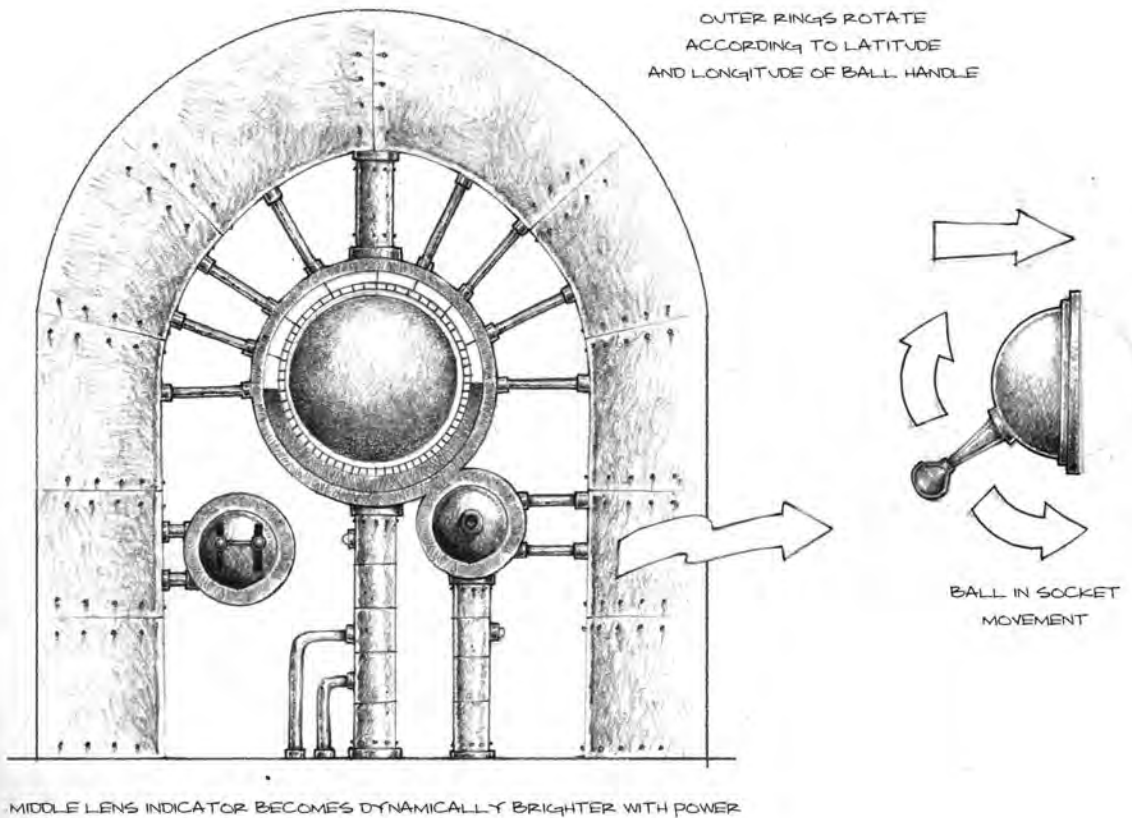

Noloben

The Pool

Upon linking into Noloben, I exited the shimmering bubble around the first pedestal and turned to my left, where I saw Esher sitting on the sandy beach. I approached him, and he told me that Noloben was his Age, the Age he fled to when D'ni died. He cautioned me that I would have to learn to survive here, as he had (see sidebar). His tone gave me cause to wonder what exactly transpired between him and the Bahro.



Esher claimed Noloben as his own.

Esher's Speech

Welcome to my Age: Noloben. When D'ni died I fled here. From death to death. You will see the fingerprints of the creatures everywhere—this was their home, and they did not welcome me.

To survive, I was forced to learn. You will learn here as well. It is not like the other Ages.

I continued down the beach and found a dais under a canopy. On the dais were four stone bowls surrounding a large egg-shaped rock. The rock and bowls all had shadows engraved into the dais at a 45-degree angle. The stone wall behind the dais was decorated with a variety of crudely etched symbols. At the base of the dais was a glowing symbol, similar to the other Slate symbols I had seen in other Ages.



Four bowls, an egg-shaped rock, and a glowing symbol, all under a canopy



The (upside-down) symbol for "rain"

I returned to the first pedestal, picked up the Slate, and brought it over to the dais. I etched the glowing symbol onto the Slate, placed it on the beach and stood at a distance from it as a Bahro appeared. It seemed to be confused by what I had written on the Slate and linked away without doing anything. Perplexed, I again drew the symbol on the Slate, only to be met with the same reaction. Finally, after looking at the shape of the Slate and the shape of the stone that the symbol was engraved on, I realized that I was drawing it upside-down. I tried drawing it again (with the three circles at the bottom of the Slate and the vertical lines above them), and this time, the Bahro appeared and summoned a heavy rainstorm.

I stood underneath the canopy in an attempt to get some shelter from the rain, but the canopy didn't offer much in the way of protection. In fact, it had four holes cut above the four bowls that funneled the water directly into the bowls. When the rain stopped approximately 90 seconds later, the four bowls were exactly full to the brim, and each reflected a symbol from the wall behind them.

Noloben

It all seemed too deliberate to be a coincidence. I was almost certain that this was designed to be some sort of reflecting pool. Standing directly in front of the reflecting pool, I took a few pictures of it for future reference, paying special attention to the four symbols reflected in the bowls. After a couple of minutes, the water drained from the bowls, and the reflecting pool resumed its original appearance.



Four symbols reflected in the pool—a clue if I'd ever seen one...but what was the puzzle?

The Little Island

Continuing down the beach past the reflecting pool, I came to a tunnel in the rock wall. As I proceeded through the tunnel, I was startled by the appearance of a slithering snake that brushed past my foot before ducking into one of several holes in the ground.

There was nothing of particular interest on the beach at the other end of the tunnel, but I was able to reach a second, smaller island by wading through the shallow water between it and the main island.

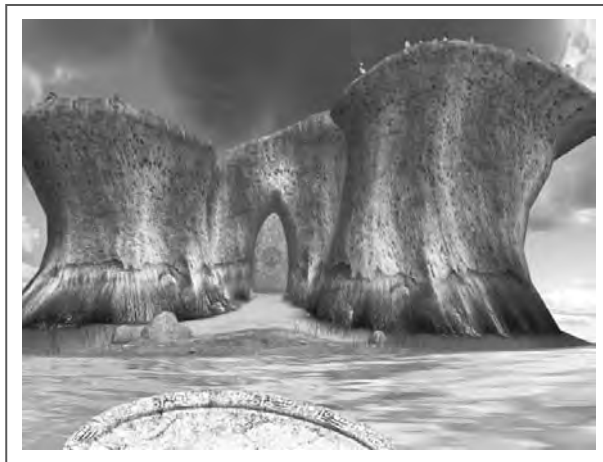

A second, smaller island that I could wade to

The narrow strip of beach at the front of the little island did not seem remarkable in any way. A cave entrance at the front of the little island was sealed by a large boulder with the inscription of a tree carved into it.

Having nothing else to explore on the little island, I made a note of the tree design on the boulder and returned to the first pedestal on the main island to drop off the Slate and plan my next move.

The Plateau

Having explored everything I could reach to the left of the first pedestal, I decided to take a look at what was to the right of it. I found a second tunnel through the rock wall just beyond the first pedestal, but it came to an abrupt end at a man-made obstruction before I could proceed too deeply into it.

Near the tunnel entrance, I saw a cluster of seven holes in the ground, similar to the one I'd seen the snake disappear into in the first tunnel I entered. I wondered what it was about this small strip of beach that made it such an attractive snake habitat.

While studying the snake holes, I happened to look up and see a pull cord hanging from the top of the rock wall. I looked farther up and saw a rolled-up rope ladder next to it. Pulling the cord dropped the ladder, which I climbed up to reach an expansive grassy plateau.



The second tunnel dead-ended.

Noloben



I pulled the cord near the snake holes to drop a ladder.

The plateau was dominated by a huge egg-shaped rock in the center of it. The rock was decorated with carvings similar to the ones found at the reflecting pool. Fifteen windows in the rock could be opened, affording me glimpses of some sort of laboratory inside of it—Esher's laboratory, presumably. A large lens shone brightly at the very top of the rock.

A Bahro Home

The huge, round, cave-like rock structure on the center of the grassy plain in Noloben is very much like the Bahro caves seen in other D'ni research (see Uru: The Path of the Shell). In fact, this rock structure was originally a Bahro dwelling. The same Bahro symbols are etched in the walls. Until Esher came, who knows how long they lived here in peace?

Spaced evenly around the exterior of the rock at 90-degree intervals were four smaller rocks, with rotating domes engraved with more symbols. Small stone pathways stretched between the small rotating rocks and the large laboratory dome.



Four small rotating rocks and a large laboratory dome

The arrangement of the four small rocks and the one large egg-shaped one recalled the arrangement of the items in the reflecting pool. Even the shadows engraved into the reflecting pool's dais echoed the shadows of the structures on the plateau. I also noticed that the four symbols I saw reflected in the pool's bowls were engraved on the interior wall of the laboratory, one above each window.

Bahro Numbers

Noloben is filled with Bahro writing. The majority of it is meaningless to us; there is simply not enough information to even hope to translate it. One set of the symbols, seen on the walls of Esher's lab, however, boasts a distinct pattern and appears to be the numbering system used by the Bahro.

Like D'ni numbers, this new counting system has a logical symbol progression that makes it easy to determine other numerals.

Some people come to new Ages to explore the beautiful landscapes, the exotic wildlife, the fascinating technologies. But many come to learn the power of new languages and counting systems that can further the understanding of the sentient beings who use them.

It took me a little while to realize that I was dealing with two different sets of symbols. One set was used in the reflecting pool and on the inside of the laboratory. The other set of symbols was used on the exterior sides of the laboratory windows and the smaller rotating stones that surrounded the laboratory. I sat down in the grass to ponder the puzzle, nearly stepping into one of several more snake holes that dotted the plateau.

Noloben

I was sure that the reflecting pool on the beach was the key to this puzzle. And I knew each laboratory window had one symbol on its exterior surface and a second symbol engraved above it on the interior of the laboratory. Maybe the two sets of symbols corresponded to each other? That is, maybe the symbol engraved on the exterior of a window's surface corresponded to the symbol engraved above it on the interior of the laboratory?



Each window was marked with two symbols—one on the interior of the lab, and one on its exterior.

I started by shutting all of the laboratory windows except one and looking through it to find a symbol inside the laboratory that I recognized from the reflecting pool. Once I did, I walked around the laboratory and opened the window that I thought was directly below the symbol. Returning to the first window I had opened, I looked through it to see if the second window I had opened was the correct one. Through this painstaking process of trial and error, I was eventually able to match the four pairs of symbols:

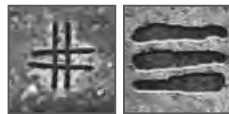

Pair #1



Pair #2



Pair #3



Pair #4

Now that I knew which symbols from one pair corresponded to the symbols from the other pair, all I had to do was turn each smaller rotating stone so that the marker on the back of it lined up with the appropriate symbol.

But which symbols went with which stones? The clue was in the shadows engraved onto the dais of the reflecting pool. Having spent a considerable amount of time in Noloben, I noticed that the sun in the Age didn't move, or if it did, it moved much more slowly than the one I was used to. As a result, the shadows of the laboratory and rotating stones never moved either. All I had to do was match the shadows of the rotating stones to the engraved shadows of the reflecting pool bowls and set the rotating stones to the symbols that were paired with the symbols reflected in the corresponding bowls.



Stone #1—shadow pointing directly away from laboratory



Stone #2—90 degrees clockwise from stone #1

Noloben



Stone #3—shadow pointing directly toward laboratory



Stone #4—90 degrees clockwise from stone #3

After waiting for a dark cloud to pass by the sun, I looked at the shadows of the smaller rotating stones, consulted my notes, and set the stones as shown.

Esher's Laboratory

As I turned each stone, I heard a rumbling deep within the plateau. Recalling the blocked tunnel near the rope ladder, I set all four rotating stones to their proper positions and climbed back down to the beach. When I returned to the tunnel, I found that the stone that had originally blocked the entrance was now turned to reveal a doorway through it.

I continued through the tunnel, passing through three additional stone doorways, one for each of the rotating stones I had set atop the plateau. At the end of the long and winding tunnel, I came to the bottom floor of Esher's laboratory.



The stone had turned to reveal a passageway.



The second pedestal

The first thing I saw was the Age's second pedestal, engraved with its glowing blue symbol. I recorded the symbol in my journal and started climbing the stone stairs leading up into the main floor of the laboratory.

Halfway up the stairs, I was startled by the sudden appearance of Esher. Whether he had just linked in or was there waiting for me, I couldn't tell. He was impressed that I had managed to unlock his laboratory, which he claimed was "safe" from the Bahro, who feared the image of the snake. I recalled the many snake holes around the island and realized that they must have been a defensive mechanism Esher employed to keep the Bahro away from his laboratory. There was no doubt



Esher said that the Bahro feared the snakes and the image of them.

in my mind that his early interactions with the Bahro were not pleasant, for either of them. He alluded to the terrifying power of the Bahro and advised me to proceed to the top of the laboratory in order to continue my journey.

Esher's Speech

You have unlocked my lab. Impressive. It is safe here, they are afraid. They will not come here. The snake binds them—prevents them from linking. I take no pleasure in what they have endured here, but I had to learn.

Did you know that you aid the creatures, the Bahro, as you move the Slates? Did Yeesha tell you that? Did you know that the full power of the Bahro is restrained by the Tablet? Did Yeesha tell you that? Did you know that they will not come near anything with the symbol of the snake? Did you know that the Tablet that Yeesha told you not to give her, controls them? Did she tell you that?

I have learned. They are terrifying creatures if not controlled.

Go to the top of my refuge...up there. Seal this refuge and you can climb.

I continued climbing the stairs, which ended at a rickety wooden platform. At the end of the platform was a ladder leading up farther, as well as a crude bulletin board with several scraps of paper on it. One in particular caught my eye; it seemed to be a sketch of a Slate symbol. Its curving shape echoed the one Esher drew in the air with his finger when referring to the Bahro's fear of "the symbol of the snake."

I climbed up the ladder to reach a cage high above the floor of the laboratory. What kind of experiments had Esher been doing here? No wonder the Bahro feared the laboratory...



The symbol of the snake

Noloben

Esher has spent the past 200 years in the Age of Noloben. It is a place of majestic outcroppings and swaying grasses. The sandy shore houses birds and snakes and other wildlife. Esher seems most at home here; he is both proud and comfortable in these surroundings.

His lab, however, shows us another side of Esher. Here he carried out experiments by caging the Bahro...who knows for how long? He has worked many long hours to understand these creatures. What is the reason for his obsession? Is it the power of the Tablet? Or is it the creatures themselves he longs to "hold"?

A ladder on the side of the cage allowed me to climb to the top of it, but the ladder leading up to the roof of the laboratory was retracted. I remembered that Esher told me to "seal this refuge" in order to climb up there.

That didn't seem as if it would be too difficult. After all, the second pedestal was at the floor of the laboratory. All I had to do was pick up the Slate, draw the second pedestal's symbol on it, and lay it on the ground for the Bahro to pick up and bring to the second pedestal.

However, when I returned to the first pedestal and put my plan into action, I found that the Bahro would not link to the second pedestal with the Slate. At first, I thought I had drawn the symbol incorrectly, but then I remembered that Esher said that the Bahro wouldn't go anywhere near



The ladder to the lab roof was retracted.

Noloben

the laboratory. That meant that to create the link between the first and second pedestals, I had to draw the second pedestal's symbol on the Slate and physically place it on the second pedestal to create the link.



I drew the second pedestal's symbol on the Slate and placed it on the second pedestal.

The Snakes!

The Bahro are afraid of the snakes. Knowing this is both amusing and useful to the holder of the Slate. But what seems at first to be a minor aversion to the animal is quite literally a debilitating fear of both the creature and the symbol for the creature! Esher extracted the venom of the snakes which populated the beaches and caves of Noloben and experimented on the Bahro. He learned this toxin caused paralysis in the Bahro, making it impossible for them to link away. It is no wonder that the Bahro would not venture into the lab, nor touch or go near anything which bears its symbol or its shape!

After placing the Slate on the second pedestal, I returned to the first pedestal to make sure that the second pedestal's symbol appeared on its base. Once I confirmed that it was there, I climbed back up to the plateau and moved one of the rotating stones to seal off the tunnel leading to the laboratory. I then returned to the first pedestal and used it to link to the second pedestal. Leaving the Slate on the pedestal, I climbed the laboratory's

stairs and ladders and found that the ladder leading to the top of the lab was now extended.

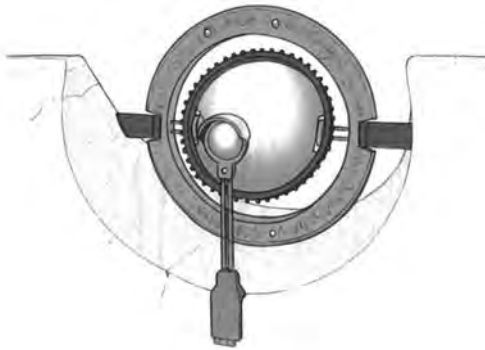

I could now climb up to the top of the laboratory.

Accessing the Little Island

At the top of the ladder was Noloben's third pedestal. I recorded its image in my journal and examined the large lens behind me. It was focused directly on the sealed door of the little island I'd seen earlier. The same illustration of a tree that appeared on the door of the small island was etched into the ground in front of the lens.



The third pedestal

When I stepped onto the tree symbol, it started to glow. Looking through the lens, I noticed that the tree symbol on the little island's door glowed as well, and the door opened as long as I stood on the tree symbol. The view from the lens teased me with a blurry view of the Keep, hidden away inside of the little island.

The Symbol of the Grower

The tree was a common symbol used throughout D'ni history. This particular symbol is a powerful one to all D'ni and to the Called. It is known as the symbol of the Grower.

In the legend of the Grower, the tree symbolizes the new life just waiting to burst forth when finally the Grower appears. To find it here, in Esher's home world of Noloben, is puzzling. Who put the symbol of the Tree on the door of the Keep? Esher may be the Grower. Was it he who carved the symbol? Does this symbol perhaps mean that, indeed, Esher is the Chosen D'ni?

Did the Bahro put the symbol on the door to the Keep? Do they wish to tell us something?

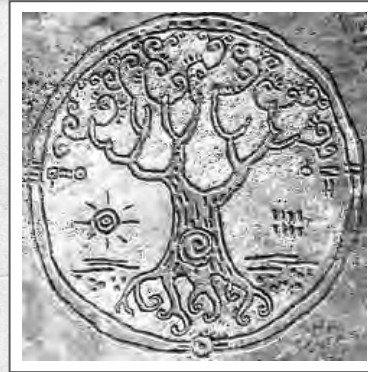

I stepped off of the symbol and was dismayed to see that the little island's door closed again. How was I going to keep it open? Perhaps if I placed a heavy enough object on the tree symbol, the weight would keep the trigger mechanism depressed while I traveled back to the little island. The Slate was heavy enough to crack the ice in Tahgira; maybe it was heavy enough to do the job here? But how would I keep the Bahro from linking in and taking the Slate? There were no snakes up here to stop them from doing it.



The door stayed open as long as I stood on the symbol.

That's when I remembered the snake symbol from Esher's laboratory notes. If the Bahro truly feared even the crudest image of a snake, maybe that would keep them from taking the Slate.

I couldn't climb ladders while holding the Slate, so I returned to the second pedestal, picked up the Slate and used the second pedestal to link back to the first pedestal. Now it was time to test the power of the snake symbol.

I etched the snake symbol into the Slate and put it down on the beach near the first pedestal. I backed away far enough to encourage the Bahro to appear and pick it up, but I stayed close enough to observe its reaction. As soon as the Bahro realized what was written on the Slate, it panicked and linked away without taking it.



The Bahro would not touch the Slate as long as it bore the symbol of the snake on it.

With the Noloben Quest almost complete, I decided to take a few moments to record my experiences in my journal. After a couple of minutes, however, I was startled by the reappearance of the Bahro. It picked up the Slate and brought it back to the first pedestal without any fear whatsoever. Was Esher wrong about the warding power of the snake?

I conducted a few more experiments with the snake symbol and realized that

Esher was not wrong. However, he also neglected to mention that the snake symbol would fade shortly after the Slate was placed upon the ground. As soon as the snake symbol was gone, the Bahro came for the Slate and brought it back. I made a mental note of this before drawing the third pedestal's symbol on the Slate and laying it on the beach. A Bahro appeared and linked with the Slate to the third pedestal. I followed via the third pedestal link that appeared shortly thereafter on the first pedestal.

Noloben



The third pedestal link

I drew the snake symbol on the Slate and placed it on the tree symbol in front of the lens. I was disappointed to find that the tree symbol was not a pressure-sensitive mechanism, however. It seemed to react only to the presence of a living body standing on it.

Since I couldn't stand on the symbol and enter the little island at the same time, I needed another living being to trigger the opening

mechanism. Esher was nowhere to be found, which left only...the Bahro!

I remembered that the snake symbol would fade in time, so I again drew it on the Slate and placed it on the tree symbol. I then used the third pedestal's link to return to the first pedestal, and from there, I ran as fast as I could through the tunnel to reach the little island. I waited in front of its door long enough for the snake symbol to fade and the Bahro to retrieve the Slate. When the Bahro appeared, it stepped on the tree symbol above the laboratory, which opened the door to the little island, granting me access to the Keep.

I made a note of the symbol for the Keep and touched its link to return to the first pedestal, where the Bahro had returned the Slate. I drew the Keep's symbol on the Slate and dropped it. The Bahro appeared and linked with the Slate to the Keep. I followed it via the Keep link on the first pedestal.



The Bahro opened the door for me unwittingly.

When I linked to the Keep, Esher appeared and launched into an angry rant, accusing me of allowing Yeesha to plant doubts about him in my mind (see sidebar). After calming down a bit, Esher said that there was another option for what could be done with the Tablet: It could be taken to Myst, an Age that Yeesha vowed never to return to. There, Esher claimed, it would be safe from her.



The Keep symbol



Esher seemed almost paranoid when I met him in Noloben's Keep.

Esher's Speech

No one understands these creatures as I do. I see you doubt that. No one has learned their language as I have. Do you question that as well? What other doubts has she placed in your mind? I have opened my Age, my mind, and my understanding. And yet, still, you question my motives.

I only hope the knowledge I have gained will save you and me in the end.

Why do I pace? I am afraid. I fear what you will choose in the end. I hesitate to tell you this; to add to your burden...but I must. There is another option in the end.

The Myst Book. It lies locked on the desk where you began in K'veer. Yeesha will not go there—she has grown to detest that island, so the Tablet would be safe from her hunger for it. Be alert, a choice awaits. Do not let your feelings of doubt, perhaps even of me, cloud your reason.

Noloben

I was three-quarters of the way through the Quest, and yet I was still no closer to knowing what I would do with the Tablet once I unlocked it. Esher seemed to be becoming progressively less stable as I neared the end of the Quest, genuinely terrified that I might give the Tablet to Yeesha. Yeesha herself instructed me not to give it to her, but her hunger for it was obvious. And if someone with her power decided she wanted to take it from me, could I even stop her? The Tablet promised absolute power, enough power to corrupt absolutely. I wasn't even sure that I wanted to take it in the end, but the call of the Quest was too strong to resist. I placed my hand on the Slate to unlock the third of the four Tablet locks, and then I linked back to Direbo via the pedestal links.

Return to Direbo

From Direbo, I used the Linking Book on the Noloben island to return to the D'ni rest area I had linked in from (Rest Area C). I returned to the section of the floor of the Great Shaft that I had raised and pressed the red button in the center of it to lower the floor again.

So far, I had found every D'ni rest area by descending farther down the Great Shaft. I hadn't reached D'ni yet, so I obviously had farther to go. The doors leading to the yellow and blue switches were now sealed, so the only option was whatever was under the floor of the Great Shaft.

I pressed the red button again, but this time instead of staying on the floor as it rose, I ran off of it to the perimeter of the room. The floor rose without me, revealing several ladders leading down into a pit below it.



Continuing The Descent



The Descent to D'ni continues...

In the center of the pit beneath the floor was another switch that would presumably lower the floor again, though I didn't press it to test the theory. Next to the switch was a Yeesha journal, which I picked up and read (see sidebar).

Yeesha Journal VIII

Home was far behind—I was no longer a child. I journeyed deep—deep within myself, deep within the earth, down to the D'ni cavern. I was alone for a time as I consumed my heritage, breathing deep the air of the cavern and the knowledge of my people.

But the desire for companionship drove me mad. I engaged a senomar as my confidant, and a tredfish in the harbor became my younger brother. I spoke to them as family and they answered, I swear they answered.



Then my mind took a final step into madness when I walked into the library on Ae'gura and saw an old D'ni man on the floor below me. Now I was imagining people to ease my loneliness.

But he was no mirage—his name was Calam. And he was a D'ni Writer of Ages.

Trust did not come easily. There was conflict between us—between his ancient rules of D'ni that I did not respect, and my creativity, which he feared. We fought and feared and battled and screamed, until exhausted, we began to learn from each other. We learned of the power of both, just as Father and Mother had done.

So I learned to Write with all the skills that the D'ni had known—beyond what my parents had taught me. For their lessons were given by a flawed instructor and by their own trial and error. I learned to Write from a Master: an opportunity Father was never given. Calam's abilities were breathtaking—he knew all the D'ni knew, when D'ni fell.

But I taught as well as learned. There were things that the D'ni were forbidden to Write, words they feared, concepts they shunned. Rules and boxes. I had no cultural fear of such things, so I dug deeper, asking questions that Calam could not answer. And together we sought answers.

That is how we learned of the Bahro and the Tablet. I learned of its power. We grew in knowledge and strength, and Calam became one of my dearest friends. I began to think that it was he who would be the Grower.

But evil will find you, even in the depths of the earth, and Calam was murdered.

I proceeded down a long tunnel leading away from the center of the pit. It ended at a switch, to which several large pipes were connected. I flipped the switch to set a large exhaust fan into motion above me. When I backtracked down the tunnel, I saw that a ladder had fallen from the ceiling.



A D'ni exhaust mechanism?



Another Yeesha journal and a door back to the main floor of the Great Shaft

Climbing the ladder brought me up to another tunnel with an open door at one end and a sealed door at the other. I approached the sealed door to find another Yeesha journal (see sidebar). A switch next to the journal opened the door, which led back to the floor of the Great Shaft.

Yeesha Journal IX

Power is a gift. Power is a curse.

I learned of the fearsome power I wield on that day—the day of Calam's death. In a fit of rage I destroyed the murderer, and I destroyed my innocence.

And again I learned that most things cannot be returned to how they were.



And my power continued to grow even as I began to see that the prophecies of the Grower might speak of me. My destiny began to be fulfilled. But there was still more.

The Least. Abused. Mistreated. Misunderstood. Ignored. They were mocked and scorned and their hearts still show their pain, but they continue to serve.

Such power they have, and yet they serve. They treated me with kindness, and I learned from them. They respected what I was becoming. With them I learned new laws, new rules, and new powers. I used the powers to care for a tree to come, and the Tablet allowed me to grow beyond Ti'ana, beyond Father and Mother, beyond D'ni, beyond Calam.

The Tablet held them. The Tablet chained them.

The Tablet held me. The Tablet empowered me.

I watched with them. I waited with them. I learned with them. I called them from captivity and grew while they gathered. Together we became both weak and strong.

And then my time came. My time to take the Tablet. My time to choose. I was ready. I felt the pull of holding it, of channeling and releasing the full power of the Bahro. I would right the wrongs, I would set things the way they should be. I would choose well—I could not fail. I am the Grower.

I was so sure, so strong, so wise, but I didn't open myself and listen to the Maker. The noise of me drowned his quiet voice.

And I failed. Failed to see anything beyond myself and what was obvious. And pain came quickly, when I realized what I had done. The Tablet returned, and the Bahro continued to serve. The pain still burns me.

But the powerful Bahro simply wait and serve.

Pain is often how we learn. But it is not for us to give—we are not the teachers. We must not abuse them. We must not abuse the Bahro.

I explored the other end of the tunnel, which ended in a hub room with two doors. The fan I activated minutes ago spun below the center of the room. One of the doors was locked, and its switch was broken, but I found another Yeesha journal next to it (see sidebar).



The tenth Yeesha journal,
next to a broken switch

Yeesha Journal X



How could I have not seen the true path? I see it now so clearly. But can I get another chance to make things right?

They came. They came to D'ni—those who felt called. I knew they would. I was prepared for them, and I pointed the way. I spoke often of the pride of D'ni, of their belief in their own

power and strength and the reason that D'ni once fell. And a few understand. And they begin to follow me. I am the Grower—I would lead them to rebuild.

Yet another burden.

But what is the task of a Grower? My father wrote another Age, but I see that the tree is not a place, but a people—the heart of a people. That is what must grow.

If only I had another chance to make things right. The Tablet is the key—how could I have failed?

Rest Area D

The other doorway led into the fourth and final D'ni rest area. The last Yeesha journal sat on a bunk along the side of the wall (see sidebar). As with every other rest area, this one contained a Linking Book to Direbo. After picking up the journal and reading it, I placed my hand on the Linking Panel and linked to Direbo's fourth island.



The eleventh Yeesha journal

Yeesha Journal XI

I know what to do. I see it so clearly. One more chance to determine the destiny of the Tablet. I can feel it.

To be so close and yet be so powerless—it drives me mad. The Tablet sits there, holding the power of the Bahro captive, and I alone know what to do. I failed once, but what does that mean? Why am I punished when I could accomplish so much? The rules seem so arbitrary—some game of the Maker that only he understands.

This legacy of failure. And now I see this final chance to right generations of wrong. To unleash the power that has been held for thousands of years. It is at my fingertips. I know what must be done, but I cannot speak of it, for fear that it would somehow break the rules—tarnish the heart, taint the act, soil the innocence.

I had a dream...



I am carrying the seed of D'ni, the seed of all things that are D'ni, through a small cave. And I come to a place where the path stops, and there are two holes—one above me, and one below me. And through the hole below I can see the D'ni cavern and the great city. And through the hole above I can see the sky and sun.

A voice calls to me "In which hole will you plant the seed?"

And I know it is easy to drop the seed in the hole below, and I know it is impossible to throw the seed through the hole above. I call out to the voice, asking for wisdom.

And the voice answers me "Do not drop the seed in the hole below, for that is easy, but that is the way of the past. Do not throw the seed in the hole above, for that is difficult, and that is the task for another. In which hole will you plant the seed?"

And I know what to do.

And I know I am the Grower.

Just as I had in every other visit to Direbo, I opened the two bridge gates on the island I linked onto. All eight bridge gates were now unlocked, allowing me free passage from one island to another. I then stepped into the shimmering bubble and placed my hand on the linking symbol that would transport me to Laki'ahn.



Laki'ahn

Arrival in Laki'ahn

Upon linking into the island Age of Laki'ahn, I exited the translucent bubble surrounding the Age's first pedestal and saw Esher standing at the front door to a great stone building. I approached him, and he told me of Laki'ahn's history (see sidebar). As he described it, Laki'ahn seemed to be the site of some great and glorious battle. Esher referred to the building behind him as the "trade house." The front door was locked, but he told me that a "jeweler's door" in the rear could be unlocked.



Esher remembered Laki'ahn as a "place of great strength and triumph."

Esher's Speech

I wish you could see Laki'ahn as I remember it. Anticipation. The calls of the beasts bellowing out over the warm airs and conversations, as we waited for the fires to burn and the battle to begin.

This was a place of great strength and triumph. I wonder if you possess such courage.

The door to the trade house is locked, but the jeweler's door on the other side—that can be unlocked.

After Esher linked away, I tried the front doors to the trade house and found them securely locked, just as Esher had told me. The windows were also impenetrable, but looking through them, I saw a scrap of paper with a series of shapes drawn on it. It seemed important, so I took a picture of it before exploring the rest of the island.



This might come in handy later—five geometric shapes on a piece of paper.

Boneyard

Returning to the first pedestal, I turned right, toward the beach, and walked along the beach toward a wall made of stone blocks and reeds. Following the wall away from the trade house, I found a small passageway between several large boulders that overlooked a boneyard for beasts of incredible size.

Judging from the lack of legs or other appendages on the skeletons, I assumed that the beasts must have been aquatic creatures. The cracked earth of the boneyard indicated that the area must have been filled with water at some point. A large broken mechanism loomed over one end of the boneyard. It looked as if it might have been a crane, designed to lift the creatures into and out of the water. I guessed that this boneyard might have been some sort of aquatic zoo in years past, its inhabitants condemned to a slow death when D'ni fell and no one was left to maintain it.

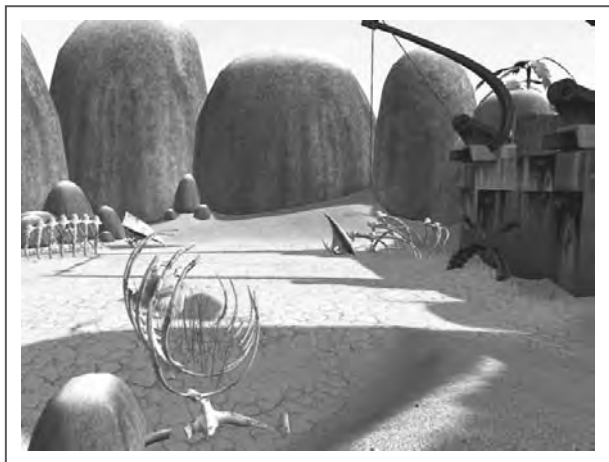

The remains of an aquatic wildlife preserve?

Laki'ahn

Across the boneyard from the crane mechanism, a glowing symbol etched into a nearby rock stood out prominently. I copied this first Slate symbol into my journal and returned to the first pedestal to pick up the Slate and see what effect the symbol would have.

I drew the symbol on the Slate and placed it on the ground, backing away from it. A Bahro linked in and raised its hands in a display of power. Suddenly, a gale-force wind whipped across the entire island. I stumbled over to the Slate, picked it up and stood behind a boulder for shelter. As with other Bahro effects in other Ages, the unnatural wind came to an abrupt end approximately a minute and a half after it began. I resolved not to use that symbol again unless I had a good reason!

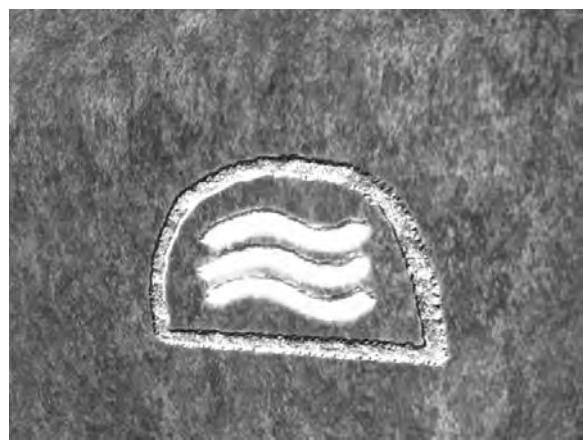

The first Slate symbol of the Age

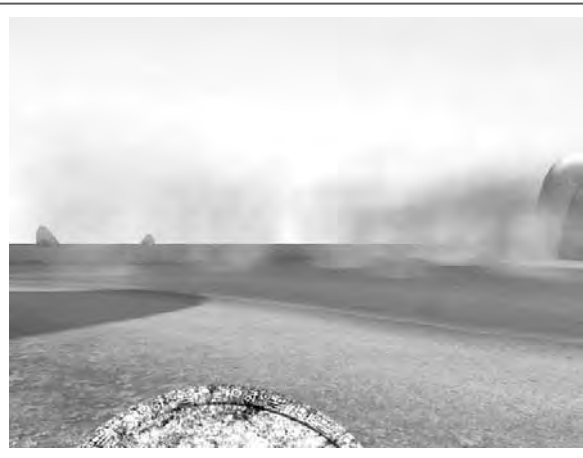

An unnatural gale-force wind, triggered by the Bahro's reaction to the Slate symbol

Forces of Nature

The Bahro are able to read and understand symbols and carry the Slate to a designated spot. However, there are other symbols, the "Nature Symbols" which the Bahro read and then are able to affect environmental changes—the rain in Noloben, the temperature in Tahgira, and the wind in Laki'ahn. What extraordinary powers the Bahro must possess to be able to change the very makeup of a world in these incredible ways!

The Windmill and Cages

I returned to the boneyard and walked directly across it to find another pathway leading between the boulders that led to a small stream, littered with the skeletons of more of the aquatic beasts. The triangular mouth of a gigantic holding pen yawned wide in front of me. I waded into the stream and entered the pen.



A holding pen, presumably for the aquatic beasts

The Holding Pen

As I advanced down the length of the holding pen, I was hit with a stench so strong that I nearly gagged. The clear blue water turned dark and slick, and offal floated along its surface, no doubt the desiccated remains of one or more of the water beasts.

Holding my nose, I moved to the far end of the holding pen and saw what appeared to be a submerged pedestal inside of a cylindrical cage. It didn't take long for me to realize that there was nowhere else to go in the

Laki'ahn

holding pen, so I turned around and started wading in the other direction as fast as I could.

A crack in the wall outside of the holding pen allowed me to climb up onto the grassy shore surrounding it. I noted with some unease that the wall was decorated with the tusks of the giant beasts. That seemed to be an odd choice of ornamentation for a wildlife preserve...if that's what Laki'ahn in fact was.

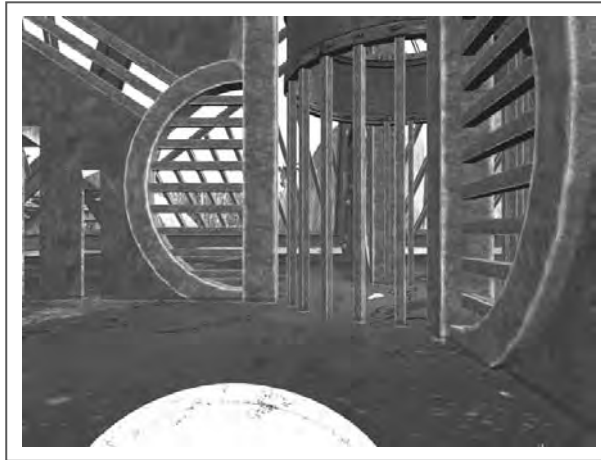
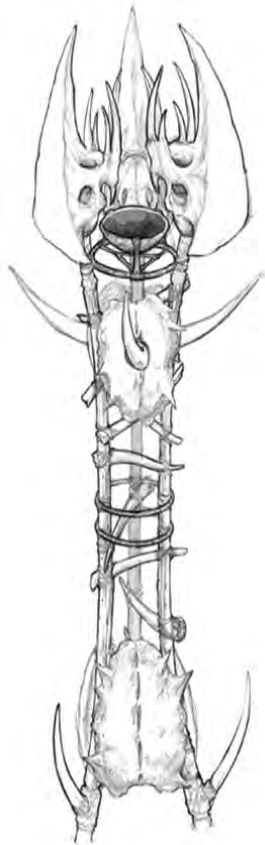

A submerged pedestal in a cylindrical cage

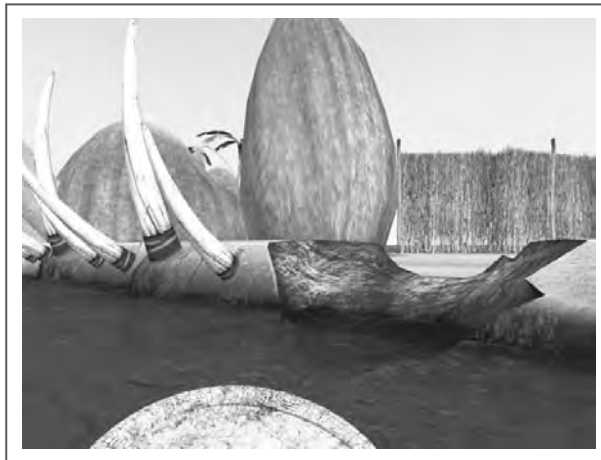

A crack in the holding pen wall, surrounded by tusks of the large aquatic creatures

The Windmill

Walking around the outside of the holding pen cage, I found a large windmill behind it. Cables strung from the windmill led to the top of the pen and seemed to extend down to the cylindrical cage that held the submerged pedestal.

I continued walking around the holding pen and saw another stream leading away from it and into a tunnel that protruded between several large boulders. The tusks mounted along the walls of the stream prevented me from dropping into it, but I knew that there must be a way to reach it.



Cables stretched between a windmill and the top of the holding pen



Another stream leading out from the holding pen

I sat and thought about what I had discovered. There was a submerged cylindrical cage inside of the holding pen that looked as if it held the Age's second pedestal. If I could get a good look at the pedestal, I could link to it with the power of the Slate, for all the good it would do me. Perhaps from the second pedestal, I could reach the other stream? I decided to take a closer look at the windmill and see if it could be of any help.

Laki'ahn

From the back of the windmill, I could access its control panel, which had three levers and two buttons on it. None of them seemed to do anything, but the windmill wasn't moving either. That, at least, I could do something about. I used the wind symbol on the Slate to order the Bahro to summon the gale again and set to work on experimenting with the windmill controls.

After some experimentation, I determined that the levers and buttons on the windmill control panel produced the following results:



The windmill control panel

- * **Left Lever:** Engaged power to the windmill. Nothing else would work until the wind was blowing and I pulled this lever.
- * **Middle Lever:** Raised and lowered the cylindrical cage in the holding pen to one of three positions (submerged, water level, above water level).
- * **Right Lever:** Rotated the cylindrical cage 90 degrees.
- * **Left Button:** Opened the cage gate to the second stream leading between the boulders.
- * **Right Button:** No effect. Presumably opened the broken cage gate I'd entered the holding pen through.

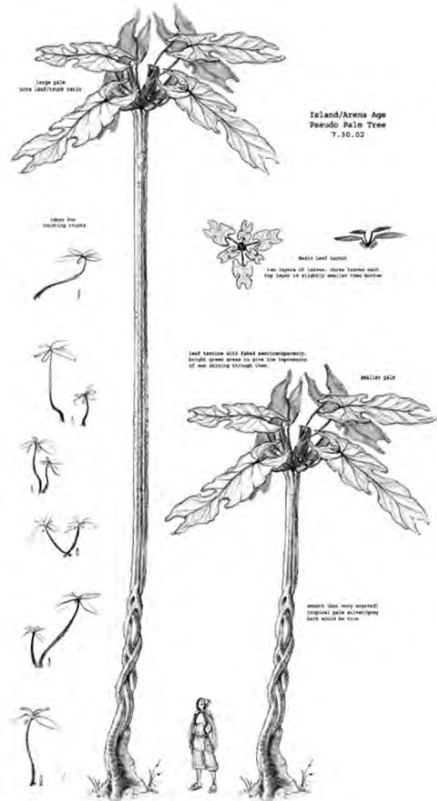

I used the windmill control panel to raise the cylindrical cage to water level, rotate it to face the second stream leading between the boulders, and open the cage gate to the second stream. Here's how:

1. Used the wind symbol to cause the Bahro to whip up a gale-force wind.
2. Pulled the left lever to send power to the windmill control panel.
3. Pulled the middle lever once to raise the cylindrical cage to water level.
4. Stepped out of the windmill control panel and re-entered the holding pen to view the symbol on the second pedestal. Recorded the pedestal symbol in my journal.
5. Started the wind blowing again; it had died down while I was copying the pedestal symbol.
6. Pulled the left lever again to restore power to the windmill control panel.
7. Pulled the right lever twice to rotate the cylindrical cage so that its opening faced the second stream.
8. Pushed the left button to open the cage gate to the second stream.



The second pedestal's symbol

Note

Had I been quicker, I could have done all of this inside the wind's 90-second duration and omitted steps 5 and 6.

Laki'ahn

With the cylindrical cage in the proper position and the holding pen's second gate open, I drew the second pedestal's symbol on the Slate and left it on the ground for the Bahro to pick up. After it placed the Slate on the second pedestal, I returned to the first pedestal and used it to link to the second pedestal. I then stepped off of the pedestal, taking the Slate with me, and waded down the second stream, wholly unprepared for what I was about to discover.



I used the first pedestal's link to the second pedestal to appear inside of the holding pen's cylindrical cage.

The Arena

From what Esher told me when I first linked into the Age, I had naively assumed that Laki'ahn was an island paradise, a wildlife reserve constructed and maintained by the D'ni to celebrate a glorious military victory. As I reached the end of the second stream, I realized that I couldn't have been further from the truth.

At the end of the stream was a vast arena, lined with stadium seating, similar to an ancient coliseum. A gate to my right led to the boneyard I'd seen earlier, which I now realized was nothing more than a holding pen for the giant aquatic creatures before they were led into the arena and forced to fight to the death.



This wasn't a zoo; it was an arena!

The Laki

The "Arena" and surrounding waterways were holding pens for the magnificent sea creatures of Laki'ahn, called Laki. The Laki were the main source of food for the Kresh—the native inhabitants of this Age. The coliseum surrounding the arena sat hundreds of D'ni visitors who watched as the Kresh fought for their food.

Looking far out to sea, one may glimpse magnificent, white-colored, giant fish. Are these the Laki? Are there more? Or have they become endangered? They do not come close to the shore for good reason. They know the village here as a place from which, for them, there is no return.

The Counterweight Mechanism

Numbly, I ascended a ramp at the end of the arena and saw the third pedestal of the Age sitting atop a wooden platform. I was just barely able to make out its symbol, which I etched on the Slate and left for the Bahro to pick up. When the Bahro linked up to the third pedestal to drop off the Slate, the platform sank. When the Bahro linked away, the platform rose again, but it did not reach the height it originally started at, presumably due to the additional weight of the Slate that was left on it. It didn't take long for me to realize that the platform's height was determined by a counterweight mechanism.

I needed the platform to remain at its original height when I linked to the third pedestal so that I could cross a small footbridge and reach the next level of the arena. That meant that I would have to set the counterweight to the exact same weight as my own, as well as that of the Slate.

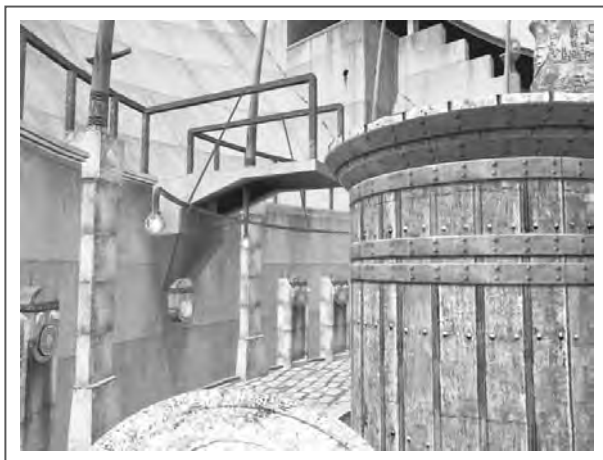

I needed to cross the footbridge at the top of the platform to reach the rest of the arena.

Laki'ahn

I used two mechanisms near the podium to solve the problem. The first was a scale, which displayed four symbols composed of concentric circles. I figured out that these were measurements of weight. Each circle in the weight symbol represented one unit of weight. For instance, the single circle was worth one unit of weight, and the four concentric circles were worth four units.



The scale

When I stepped onto the scale with the Slate, two red markers appeared next to the three-unit symbol and one appeared next to the one-unit symbol. When I stepped onto the scale without the Slate, only the two three-unit markers appeared. I took this to mean that I weighed six units, and the Slate weighed one. That meant that I would have to set the counterweight to seven units of weight, plus the weight of the pedestal on it, in order to balance it.

Behind the platform were four buttons, each labeled with a weight unit symbol. Set above each button was a pair of golden caps. Pressing a button once opened one of the two caps above it, revealing a red marker. Pressing it twice opened both caps. Pressing it a third time closed both caps. I immediately realized that these were used to determine the amount of weight for the counterweight mechanism. A large gold button directly behind the platform was used to activate any changes made to the counterweight.





Four buttons used to set the counterweight

I closed all of the caps above the four buttons and pressed the activation button to remove all weight from the counterweight. The platform sunk to ground level, and I now had an excellent view of the third pedestal and its symbol.



The third pedestal symbol

I added seven units of weight to the counterweight (for my own weight and the weight of the Slate). I estimated that the third pedestal probably weighed slightly more than me, so I added an additional nine units to balance it for a total of 16 units of weight.

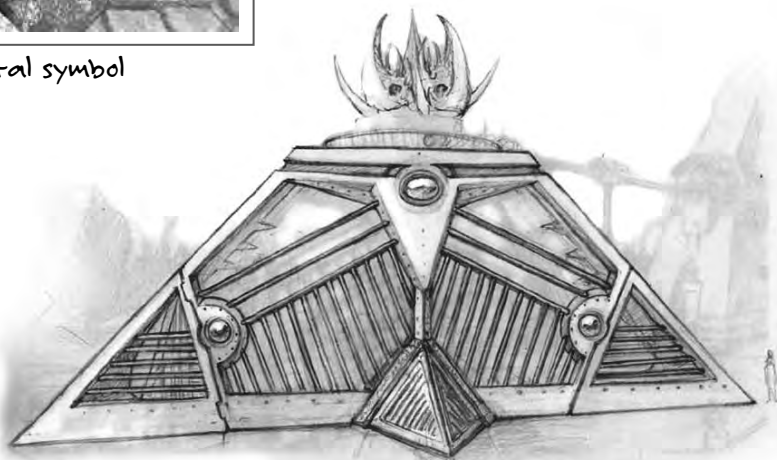

Note

To add 16 units of weight to the counterweight, I opened both caps above the four-unit button, both caps above the three-unit button, one cap above the two-unit button and neither cap above the one-unit button. It wasn't the only possible combination; any combination that added up to 16 units would have produced the same effect.

With the counterweight set, I pressed the activation button, and the platform rose back up above the footbridge to the arena's second level. I returned to the second pedestal to link back to the first pedestal, and then I linked to the third pedestal from the first while carrying the Slate. When I linked in, the platform sunk just far enough to be even with the arena's second level.



I set the counterweight to 16 weight units.

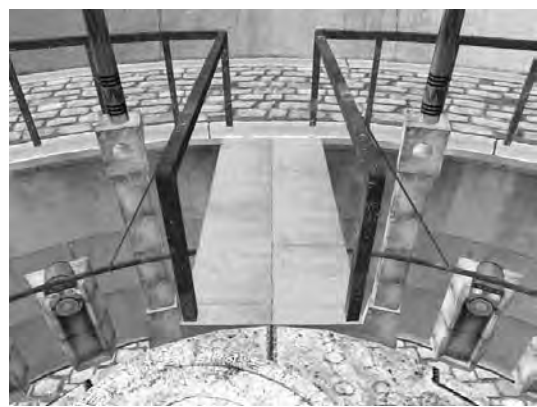

I successfully reached the arena's second level.

Entering the Trade House

I stepped onto the arena's second floor, and the platform rose behind me. From the end of the footbridge, I turned left and walked toward a red door. Esher appeared and recounted the glory days of the Laki'ahn arena, when the D'ni would watch the water beasts ("Laki") fight to the death and recover gems from their corpses (see sidebar). So enraptured was he with his recollections that he completely failed to notice the look of disgust on my face. I had no issue with eating meat, and I wasn't even particularly opposed to hunting, but forcing animals to fight each other for sport crossed a line for me. If this was the D'ni Esher wanted, I had no intention of helping him revive it.



Esher recounted the glory days of the arena.

Esher's Speech

Here, we watched. The harvest of the gems, freed from the conquered Laki and painted with their bloods. What triumph! What grand sport! What displays of strength!

Yeesha finds such strength brutal, even as she seeks it herself.

Ah...to have such fellowship with my people again....



Laki'ahn

Once Esher linked away, I approached the red door behind him and found it locked. Five buttons in the shape of geometric symbols spanned the length of the lock. Referring back to the photographs I had taken, I recalled the scrap of paper I'd seen through the trade house window at the beginning of my journey through Laki'ahn. I now recognized it as the (upside-down) combination for this jeweler's door. I touched the symbols in the following order: circle, square, triangle, hexagon, and diamond. The bolt slid back and the door opened.

I entered the trade house and walked straight toward the main entrance. With a turn of the door handles, the main entrance unlocked.

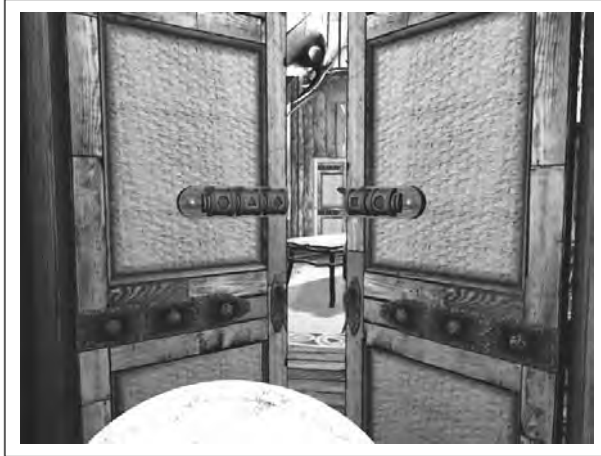

Door combination: circle, square, triangle, hexagon, and diamond

A Booming Trade

The Trade house and Jeweler were set up together to capitalize on the jewels which were gathered from the Laki, the huge creatures from the seas in Laki'ahn. The D'ni would watch as the Kresh did battle in the arena with the creatures and harvest jewels from inside the slain creatures. The fighter then took the jewels and put them on the scale (the raising pillar). There was great fanfare as the fighter put in the weight of the jewels. When the weight was correct, the pillar would rise up to the jewelers. The jewelers would take the jewels and auction them off to the highest bidder.

The fighter got to keep the meat of the Laki.

Laki fighting was great sport to the D'ni. The spectators could spend the day watching the battles and bidding on the prizes claimed from the fallen Laki.

The small trade house held few objects of immediate importance, save for a scrap of paper on one of the tables. There were no words written on the paper, only four splotches of color—red, red, green, and blue.



Four splotches of color:
red, red, green, and blue

Fighter Maze

With nothing else to see or do in the trade house, I returned to the arena and walked out onto two second-floor balconies that overlooked the water below. Each balcony had a red button at the end of it that opened a gate below the balcony. I pressed both buttons and then dropped back into the water through a crack in the wall of the lower tier of seating.

Elevator to the Second Floor

I entered one of the gates I'd just opened (both led to the same place) and followed it down a long tunnel that ended at a heavy red lever and a red pressure plate.

Near the lever and pressure plate was another elevator platform. While standing on the platform, I could make out a floor above me, which I could reach only by activating the platform.



A button on each balcony opened
gates below the balconies.

Laki'ahn

The elevator was another counterweight mechanism. The heavy red lever was the counterweight. By raising it to its highest position, I "primed" the elevator. Stepping on the pressure plate sent the elevator up to the second floor and lowered the heavy lever. When I stepped off of the pressure plate, the elevator returned to my floor.

To reach the second floor, I would have to have someone trigger the pressure plate while I stood on the elevator. And thanks to the little island door puzzle I'd solved in Noloben, I knew exactly how to do it:

I remember Yeesha mentioning something in her journals about taking the time to sing, so I drew the "sing" symbol on the Slate and placed it on the pressure plate. I then raised the heavy red lever to its highest position. Finally, I ran onto the elevator and waited for the Bahro to appear and pick up the Slate. When it did, its weight triggered the pressure plate and sent the elevator up to the second floor.



Lever and pressure plate

Note

Another heavy lever and pressure plate system on the second floor would return me to the first floor if necessary.

Through the Maze

From the elevator on the second floor, I could go down one of four hallways. Each had a colored lighted switch at the end of it. I remembered the paper with the color splotches that I had found in the trade house. I realized it was the key to getting through this maze.

Two of the hallway's colored switches were red. I chose one of them and pressed it. The hallway forked after the red switch. I turned right and approached a second red switch, pressing it. After the second red switch, I made another right turn and pressed a green switch, and then I turned left and pressed a blue switch that opened a door to the outside of the arena and the fourth pedestal.



I made it through the maze by pressing a red switch, another red switch, a green switch, and a blue switch, in that order.

Note

Although two pathways from the second floor elevator started with red switches, only one pathway allowed for pressing two red switches, followed by a green and a blue switch.

The door to the maze swung shut behind me as I exited the arena. I would not need to return to the maze, but I could have done so by pressing a button to the right of the door. Instead, I copied the fourth pedestal's symbol into my journal and linked back to the first pedestal, where I picked up the Slate and drew the fourth



The fourth pedestal symbol

pedestal's symbol on it. I put the Slate down and backed away. After the Bahro appeared and retrieved the Slate, I used the new link that appeared on the first pedestal to return to the fourth pedestal.

Fighter Hut

I walked away from the fourth pedestal toward a wrecked boat on the beach. Esher linked in again and praised my progress, telling me that the tunnels I came through were originally used by the Kresh, the warriors that the D'ni used to subdue the Laki. So the D'ni could not even dirty their own hands for the sake of their blood sport? Esher lamented the fact that the Kresh had probably returned to their "barbaric" ways after the fall of D'ni. I found his words bitterly ironic.



Esher told me of the Kresh, who captured the Laki for the D'ni.

Esher's Speech

Once again you impress me with your ability. The way has not been easy. You have come here via the way of the Kresh...the warriors, the natives who traveled here to subdue the beasts for us. What has become of them? Back to their barbaric ways. What a waste.

Yet more destruction at the hands of the outsiders who have never understood what D'ni is. And now they can rebuild it?

Continuing down the beach, I reached a crude hut that was presumably once occupied by the Kresh fighters. Another counterweight mechanism, composed of seven boulders of varying sizes, sat to the right of it. The boulders were connected to two gates as part of a counterweight mechanism.

When too many boulders were lowered, the top gate remained open, but the bottom gate closed. Likewise, when too many boulders were raised (by pulling the cords in front of each), the top gate closed and the bottom gate opened. The trick was to strike a balance so that both gates would remain open and I could enter the fighter hut. I was becoming an old hand at such things and quickly figured out that raising one large, one medium-sized, and two small boulders on the counterweight mechanism raised both gates.



The Kresh fighter hut



I raised one large, one medium-sized, and two small boulders to open the back door of the fighter hut.

I climbed through the tunnel leading up from the back gate, which I found behind the hut to the right, and came to the top floor of the fighter hut. Looking out through a window, I saw a small island in the distance and a tattered flag hanging off of the window. There was a symbol of some sort on the flag, but it hung listlessly in the still air, and I couldn't see it.

Laki'ahn



A small island in the distance

Something about the flag had piqued my interest. I drew the wind symbol on the Slate and left it on the ground. When the Bahro appeared and whipped up the wind, I looked out of the window again. I could now clearly see the flag's symbol, which looked simple enough to draw on the Slate.

On a whim, I did just that. After I backed away, a Bahro linked in to retrieve the Slate. I returned to the fourth pedestal and linked back to the first pedestal from it. A new linking symbol had appeared on the first pedestal—and it was the same one I had just drawn on the Slate! I touched the new symbol to link to wherever it would take me.



The flag symbol



The new linking symbol on the first pedestal

The Keep

I arrived on a small island that held the Keep in Laki'ahn. Esher was there waiting for me and made one last desperate plea (see sidebar). He told me that I was about to unlock the Tablet, that I would return to K'veer upon touching the final Slate. He cautioned me that, once I held the Tablet, Yeesha would appear and beckon to me for the Tablet, and that under no circumstances should I give it to her.

Instead, according to Esher, I should use the Myst Linking Book that he had unlocked to bring the Tablet to Myst, where Yeesha would not follow. There, according to him, it would be safe from Yeesha's lust for power.



Esher told me to take the Tablet to Myst, not give it to Yeesha.

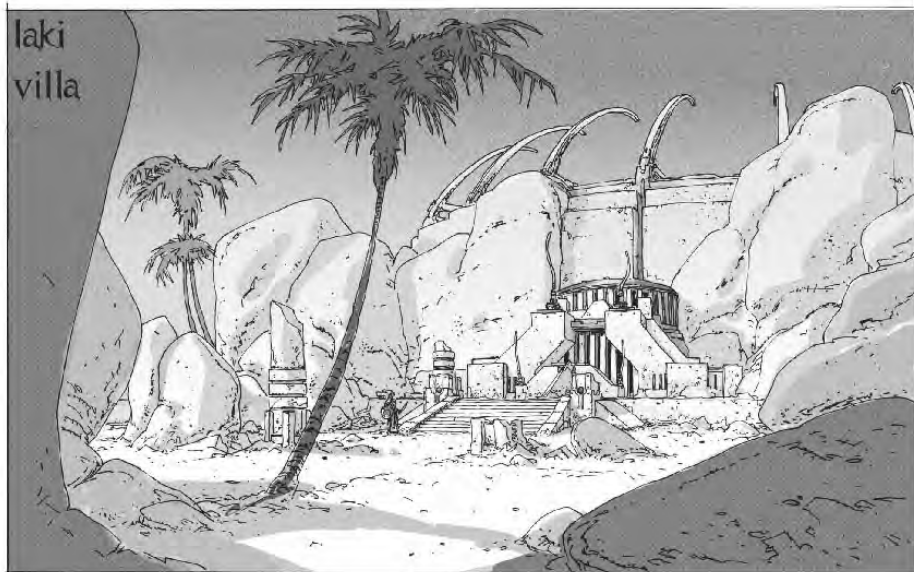

Esher's Speech

The Distant Isle. Very few have been here. You have...you have done well. Treasures were kept here and...still are. The Tablet on the Keep is perhaps the greatest treasure ever held by man or beast. And you will hold it soon.

Power is in your hands, friend, whether you like it or not.

I will not have the chance to speak to you again—you will link upon touching the final Slate. The Tablet will be yours, as will the choice. I will be blunt, for it is my last opportunity...D'ni's last opportunity.

Her mind has changed. Now she believes she must have the Tablet. She believes she is the Grower. When you see her, she will beckon for it. Do not give it to her.

But...The book...in K'veer? I have unlocked it. Bring the Tablet there—to Myst Island. Yeesha will not follow. She does not want to be their master.

Bring the Tablet to the island. There is no other choice. I will meet you there. Please do not fail. It is what must be done.

Esher linked away, leaving me alone on the Distant Isle with the Keep. I turned his words over in my head as I watched Laki swim free through the clear blue water of the Age. And as I watched them, I suddenly knew what I had to do. Placing my hand on the final Slate, I unlocked the Tablet and linked back to K'veer to complete my Quest.

The End of the Journey

The Tablet

After touching the fourth and final Slate on the Keep, I immediately linked back to the Keep in K'veer, where all four stone locks were released from the Tablet. The Tablet sat in the middle of the Keep, just waiting for me to pick it up. The only question that remained was: what to do with it now?

The one thing I knew I would not do—could not do—was give the Tablet to Yeesha. Both Yeesha herself and Esher were quite explicit on this

point. And truth be told, I wasn't sure that I could trust Yeesha with it. The stories that I had read about her always implied an edge of instability, but the Yeesha I had encountered was desperate, possibly already driven to madness by carrying the burden of D'ni for hundreds of years. And since

it seemed to be the one thing that Yeesha and Esher agreed upon, I wasn't about to disagree with them.



The Tablet was released, but the problem of what to do with it remained.



The End of the Journey

That left Esher's plan to link to Myst and leave the Tablet there. According to Esher, Yeesha considered Myst to be a cursed island and would not journey there to take the Tablet. I could not deny that I yearned to see the Age that figured so prominently into the story of the D'ni, but I could not escape the feeling that there was something that Esher was not telling me. Had I not seen the way he reveled in his memories of the Laki arena in Laki'ahn, I might have been more inclined to follow his counsel. But I no longer felt as if Esher and I shared the same perspective on what constituted the glory of the D'ni.

I approached the Tablet. Yeesha and Esher had both told me that it held the power of the Bahro, of the Least. It was through this Tablet that the D'ni had been able to use the Bahro's innate talent for linking and for reshaping the fundamental physical laws of Ages. How could one person ever be entrusted with such power? As it turned out, the question was its own answer.

Note

EDITOR'S NOTE: The best efforts of D'ni scholars have failed to completely explain the principles underlying the Art of Writing. Coupled with the mysterious power of the Bahro, the D'ni Art may well result in an infinite number of potential manipulations of the space-time continuum, possibly allowing a person to access different dimensions or "instances" of an Age. In addition to this author's account of the end of his journey, we have discovered the accounts of other travelers who made different decisions regarding the fate of the Tablet. We reprint them as sidebars here, in the spirit of acquiring a more complete understanding of the significance of the Tablet and the motivations of Yeesha and Esher.

Giving the Tablet to Yeesha

I have failed in my Quest, and my life ends here on Myst Island.

Esher and Yeesha both warned me against giving the Tablet to Yeesha. I thought I knew better than the two who were more familiar with the Tablet than any other living soul. In my pride, I approached Yeesha with the Tablet. In her weakness, she reached out for it.



Upon leaving my hands, the Tablet slipped, suddenly intangible, through Yeesha's. Silently, she turned away in despair. Silently, she linked away from K'veer. I would not see her again.

The Tablet returned to the Keep, its four stone locks binding it once again. I tried to touch it and felt nothing as my hand slid through its insubstantial form.

In a blind panic, I returned to the K'veer prison where I started my doomed Quest. True to his word, Esher had unlocked the Myst



The End of the Journey

Linking Book. I opened it and linked to Myst, an Age as ruined as my dreams for a new D'ni. Esher, furious, met me at the steps of the library in the center of it. His words still ring in my ears, the last words I shall ever hear:

"After everything...did you not trust me? After all the help I provided—all the aid and assistance? Well done, now it has slipped through her hands, wasted. Fool.

"Now your journey has been a waste, and this precious island that once represented escape is now your prison. We have all failed—you have accomplished nothing.

"And there is no way from here. No one will come for you. Myst Island is your end forever."

And with that, he vanished.

I do not know how long ago that was. There is no way of reckoning time in Myst. There is no sun visible in its dismal sky. There are only clouds and an unceasing rain.

All of its wondrous mechanisms, once capable of transporting a traveler to wondrous Ages, have long since fallen into decay.



There are no Linking Books. There is no escape. There is only water as far as the eye can see.

The island's vegetation seems to be edible. The rainwater seems to be potable. I could subsist in this manner for a long, long time.

But I will never leave.

Bringing the Tablet to Myst



Curse me for a fool for ever thinking that I could trust that wretch!

After I took the Tablet from the Keep, Yeesha appeared and reached out for it. Without a word, I hastened past her with my prize. I would not let a charlatan such as her lay claim to the most powerful artifact in the history of the D'ni, not after what Esher had told me about her. I hastened to the prison in K'veer and used the unlocked Myst Book to link to Myst, foolishly disregarding the first rule of linking: Never link to an Age without bringing with you a means of returning.

The End of the Journey

A pedestal sat inside the library on the center of the island. Its shape implied that it was designed to hold the Tablet, and so—foolishly—I set the Tablet onto the pedestal.

Esher linked into the library. "So, you listened to my wise counsel and have brought the Tablet," he said, smiling broadly. "Well done." I confess that, for a moment, I was happy to see him. I thought that I had saved every Age in existence from the threat of a madwoman. Instead, I had condemned them to the tyranny of a madman.

"There was no way for your feeble mind to comprehend the power of this Bahro Tablet. It was meant for a worthier master. You couldn't fully grasp that the master of the Tablet was the master of the Bahro, master of their full power.

"It was really only yours briefly, and only then to give to a true master. Did you think you would gain a piece of its power? Is that why you brought it? Or perhaps my words...perhaps I don't give myself enough credit. Regardless, now it is mine."



Esher's laughter echoed off of the crumbling walls of the dilapidated library. "Yes my powerful servants—your new master is here. Let's see what remarkable feats you can perform for me—the new master of the Art!

"Oh yes, thank you—idiot. You performed well enough. So, I give you this wonderful island. Consider it a Myst opportunity. Ironic isn't it? This island that was always the place of escape, has now become your prison.

"Now, let's see where this power will take me. Unlimited Ages and an army of Bahro to do my bidding.

"What fun I will have."

Esher vanished, taking the Tablet with him, and leaving me alone on this cursed island, with no hope of escape. I write these words knowing that they will never be read by human eyes.

My body will never be found. My story will never be told.



Keep Out!

Yeesha has locked the Myst Linking Book in K'veer. She keeps the Myst Book here for sentimental reasons, but she doesn't intend for anyone to use it. When Esher asks to have the Tablet brought to him, he unlocks the Book.

Myst Island is not how we remember it. Time and weather have taken their toll on the buildings and the landscape. Deserted and forgotten, the metals have rusted and the wood has rotted. As for the island foliage, it has certainly seen better times.

One forestry expert says, "Myst Island looks like an unkempt graveyard. The trees have sparse foliage and bare limbs, indicating that these trees are on the verge of perishing. It's likely that a lack of nutrition has caused this...Myst Island itself has aged to the point that it can not support life and the only thing able to survive is the scrub grass. Life as Myst Island once knew it will not be able to survive here much longer."

The End of the Journey

I could not give the Tablet to Yeesha. I dared not take the Tablet to Myst. I had no desire to retain it. If it was a Bahro artifact...then I would return it to the Bahro.

I placed the Tablet on the ground and backed away from it. Suddenly, something dark and leathery covered my face. When it was removed, the Tablet was gone as well. Yeesha fell to her knees, an indescribable expression of relief etched into the deep lines of her face.

"I am...set free," she said at last. "Their slavery of ten thousand years is over; and the burden of my family is lifted from my weary heart. Praise the Maker...he brought you for this impossible task.

"You have done well, and many will rejoice.

"You have chosen the Least...the Least as Greatest. You have freed us all: yourself of pride, me of the burden, and the good Bahro of their enslavement. You are worthy of the new D'ni."



Yeesha's relief was beyond description.

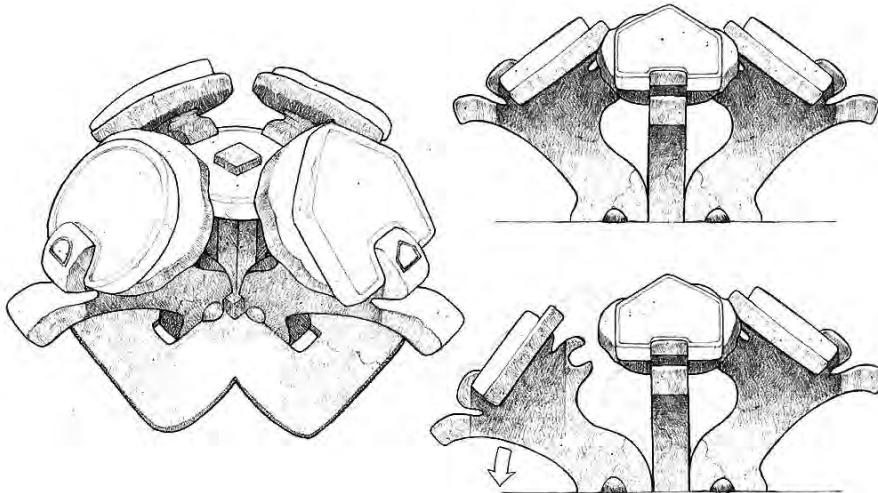

The Wings of a Bahro

When the Bahro link us into Releeshahn, it seems like something is passing across our field of vision. A hand? An arm? When we get to Releeshahn and see that the Bahro are now truly set free, one spreads his wings for us. Such a beautiful creature. But now we realize it is his wings that wrap around us to link us to Releeshahn! What other powers do these magnificent creatures possess? Each new thing we learn makes us yearn to know more.

The Bahro are by far the most powerful beings we have encountered through the Ages. What power the Tablet had on them is now broken and they are free to "spread their wings" and exercise this power fully. They are free to assume their former lives!

Hopefully, after taking the journey and earning their trust by setting them free at last, we will have the remarkable chance to spend time with them and learn more about these amazing beings.

Again, I felt something dark and leathery cover my face, followed by the sensation of linking. I arrived in a new Age, facing Yeesha and an elderly man. It didn't take me more than a couple of seconds to recognize him as the legendary Atrus.

"Oh, my father," she said, embracing him. "It's over: I didn't know if...I faltered...I...I was not always strong...I'm so sorry. But what was asked I have done. And now the tree grows again. Just to be your daughter again...hold me...."

Atrus held his daughter, his arms trembling with age and emotion. "My desert bird," he said, and then corrected himself. "No...my precious



Atrus and Yeesha, reunited at last

The End of the Journey

one...I am so sorry...for this burden. This crushing weight...I cannot bear to think of it. But you carried it. I wish your mother could be....

"You have truly become the Grower. You bring D'ni back to life. Another circle closes, another new tree grows again."

Our Old Friend Atrus

Atrus is alive and living in Releeshahn! How wonderful it is to see him again. Knowing that Releeshahn is thriving with the survivors of the fall of D'ni—and that we are free to remain here—is a fitting ending to our journeys indeed.

One regret is that Catherine did not live to see this day. She would have been so proud of us...of our choice. And how lovely it would have been to see her again! But seeing Yeesha and Atrus reunited, and getting to finally spend time with them here, in their new and final home, is the best reward a tired and weary Myst adventurer could have been given.

Atrus turned to me. His eyes shone brightly, brimming with tears, but behind them I saw a barely perceptible dullness. He looked at me and saw his anonymous friend of hundreds of years ago, the friend who had freed him from K'veer, who had assisted him in defeating Gehn and Saavedro, who had been there to rescue Yeesha from Sirrus.

"Thank you, my old friend," he said, and I did not have the heart to correct him. "Welcome to Releeshahn, this new D'ni. It's been a long, long journey—difficult journey. And I am old and weak. But I've lived long enough to see this day. To see my, my desert bird, my precious Yeesha return, as the



Atrus believed me to be his old friend.

Grower—filled with the wisdom of the Maker. Truly our long burden has been lifted. Now, my days can end. Here, in peace."

As if on cue, Esher suddenly appeared in Releeshahn, ranting and raving in the custody of two Bahro. "Oh, yes," said Yeesha with evident disgust. "There is this to deal with...."

"Let me go you—you evil demon!" Esher screamed at the Bahro. You cannot hold me...I am Esher! I am the Grower! Where is this...?"

Esher looked up and saw me. His face twisted into a white-hot rage. "You idiot! Moronic lump of filth! You are nothing! I needed the power! I needed it! D'ni needed me! You threw it away to this witch and her legion of scum! The demon slaves! You have released the slaves as masters! You've turned the small to great! Curse the Maker for bringing a fool!"



Esher was due for his just desserts at the hands of the Bahro.

"Silence!" commanded Yeesha, and Esher fell silent. Yeesha turned to the Bahro.

"You are no longer subject to the Great. You have become Great yourselves. Do with him as you should, to the Least, for I am no longer worthy to give counsel to you." One of the Bahro laid a hand on Esher's shoulder and linked away. I did not want to think about the fate that lay in store for him.

The End of the Journey

Esher's Fate

Although they have proven themselves a helpful and kind race, the Bahro have been sorely mistreated at the hands of D'ni people, such as Esher, and have been misused and misunderstood by Esher himself. Now we are left wondering—what will Esher's fate be at the hands of the Bahro? Will they be merciful? Esher certainly was not. Will he be tortured? It would certainly be fair.

From what we have learned throughout this journey, the Bahro have the resources to treat Esher in ways that would repay the torture they have received at his hand. But something tells us that the Bahro, unlike Esher, are patient and gentle.

Whatever Esher's fate is we can only imagine. But when we imagine Esher being judged by the Bahro, it is not vengeance that comes primarily to mind, but forgiveness.



Yeesha's gratitude was effusive and heartfelt.

Yeesha turned back to me, her expression softening as she struggled for words. "I am not given easily to those not close to me...but you have chosen well, my friend...and have allayed my fears.

"Many have been freed. Least will be Greatest again as it was before we began. The old is gone and the new begun to grow. This is the new D'ni—restored and free, over none, under only the Maker. This restoration of D'ni is not a restoration of the outside, of structures and stone, but of the inside—of hearts and truth.

"For kingdoms are only as strong as the hearts of their people. Your heart is right. Welcome to this kingdom. Welcome to this new D'ni."

Releeshahn—The Whole

The area the Bahro take you to in Releeshahn is the original link-in spot where the survivors first arrived from D'ni. The D'ni made a memorial structure here. It overlooks the valley where the D'ni then settled. The landscape surrounding the memorial looks eerily familiar...have we seen it before? How often have we dreamed of this moment?

Releeshahn means "the whole." This is a phrase that Atrus' grandmother continually used to try to get him to see the "big picture." He has put all of his knowledge and experience into writing this Age with that "big picture" in mind. We remember Atrus describing his effort to come up with the perfect name for his greatest work. He told us on Tomahna that he had realized the perfect name.

We are instantly and stunningly aware of Releeshahn's beauty. The majestic mountains and lush landscape surround us, and as we drink in the idyllic spot, we see that Atrus is happy here. His lifelong ambition to restore the D'ni culture and to gather up the scattered survivors must be going well.

As we follow Atrus and his daughter off the balcony we have a warm and welcome feeling of coming home at last.

Yeesha helped her father walk through the nearby courtyard gate. The remaining Bahro spread its leathery wings and began to flap them, rising into the air. Its clawed feet gripped my shoulders more delicately than I would have thought possible, and we rose into the air.

The End of the Journey

Now I could see Releeshahn, the new D'ni, in all of its verdant glory. I could see that it was a land of tranquil beauty. It was a land where burdens could be laid down and the promise of D'ni could finally be fulfilled. It was an end to struggle and to strife...and as I watched Atrus and Yeesha recede into the distance, I realized that it could well be the end of their long and painful story.



Releeshahn, the new D'ni

But if this was to be an ending, I was grateful that at least it was a happy one.



Yeesha's Journals

The following 12 journals were found by the author during his descent through the Great Shaft of D'ni. They provide an invaluable insight into the mind of Yeesha, as well as an alternate view of the history of the D'ni and her family's role in carrying the burden of their people.

Journal Prologue

These pages are my journey, my story, my path. They are not meant to cover up, but to reveal. Sometimes in poem, sometimes in story, sometimes clear, sometimes vague, sometimes long, sometimes brief. But the release of these words is a soothing elixir to my burdened soul. The words must flow from me, or I will die.

And in the end, these words are crumbs that spill along my path. And whoever eats these crumbs will know more of me.



(Discovered next to a lantern near the surface entrance to The Descent.)

Journal I

I am finding where I am, by understanding where I was.

And everything I was is linked to the island of Myst—the refuge.

And I must know where they were as well. My heritage, my people, my family.

My father, the prisoner of the hidden and the revealed. Raised by Ti'ana



(Discovered next to a lantern near the surface entrance to The Descent.)

Yeesha's Journals

who hid the truth. Then raised by Gehn, who revealed the truth. But Ti'ana hid for love, and Gehn revealed for power.

Mother too, nothing more than a slave to what she knew and what she felt. Taught by Gehn to write what she knew. Then taught by Ti'ana to write what she felt. But Gehn's teachings imprisoned her, and Ti'ana's teachings freed her.

And in the end, through the hidden and revealed, through the known and the felt, through the good and the evil, through the gods and the devils—they came together. Together they came: Father floating and Mother caring. Father knowing and Mother feeling.

And my great-grandmother Ti'ana watched, and my grandfather Gehn fell.

And so began our path of pain.

Ti'ana was called the destroyer, but she brought them together—and lived with them on Myst island.

Father could not keep Myst simple—new structures and new Ages he brought. Mother could not keep Myst solitary—two new sons she brought—my brothers—Sirrus and Achenar. And they grew up strong, and hungry, and lustful, like their grandfather Gehn—unable to control the power of Books—the power of writing Ages.

And as a result all became prisoners. Prisoners in their refuge.

I will never return to that place.

Journal II

Pride is a thief. Pride stole the soul of the D'ni people. Pride stole my own brothers. The temptation was too great. It is not the power, but the desire for power that destroys. That desire is in my blood. The blood of my ancestors—the blood of my flesh. I fight it, but I am pulled, even now.

My father tried to hide what he valued, his Books and Ages, while my



(Discovered in the uppermost rest area along The Descent.)

brothers tried to hide what they valued, riches and power. Father was trusting or naive and Ages and people were destroyed.

And so my family was imprisoned. My brothers in Ages written by Father; Father in a D'ni prison he had escaped from in childhood; and Mother in the world she loved and feared the most—Riven—her home—her refuge.

Perhaps it's why I now fear my home—my refuge.

And then by the Maker, or by the roll, a stranger found the Book. The Book had been intended to be destroyed by fire, but by the Maker, or by the roll, it was taken far away. The Book was preserved until it was time. Surely it was the Maker who preserved the Book that would bring help.

Now it was time. A stranger found the Book, came to the island and freed Father. A lesson was learned, a friendship was forged.

Friendship. The Least are my friends. I must use the Least wisely. I must listen to them. And respect them. They are powerful, they are willing, and they are afraid.

Journal III



(Discovered in a tunnel leading from a hub room in the upper level of The Descent.)

The stranger, the friend, returned again to help Father save Mother. Imagine—a stranger—traveling to Riven—risking all, asking for nothing. I think of humility, thinking more of others.

Humility: prisoners are freed by nothing more, and nothing less.

Yeesha's Journals

Gehn, my grandfather, my heritage, ugh, that monster who thought himself a god, was once again imprisoned. Perhaps he still rules that desolate, empty, and dead place, riven by the pride and bitterness of his own heart. But more likely he is in another desolate, empty, dead place, where there is weeping. I hope he is miserable. I cannot forgive him for what he did. It eats at my heart.

I hate him, because I have his same desires.

Mother and Father came again together to the refuge—to Myst Island. But it was only a shell, a place to exist—a fallen place—torn apart by pride just as the great D'ni city was.

Just as I am. Torn.

What is a stranger? Someone who is not me? Yet sometimes I feel like a stranger to myself. I become two. One who I know, and one who I do not. Where does this other one come from? Which one is me?

Journal IV



(Discovered in the second rest area as the author descended through the Great Shaft.)

I am sick of the Grower.

Oh yes, some believe in prophecies that predict the restoration of D'ni—the fallen city of D'ni would grow. There were attempts before, and there will be attempts again. But they always fail.

Even those led by my father tried. They learned great things of the Made and the Maker. They learned of the Bahro, of the Least, and of deeper truths. They learned of Father and his wisdom in rebuilding and rewriting.

The D'ni city came alive again, for a time. The dead were properly buried and the living were properly cared for. D'ni took short, labored breaths. Sap flowed, though the tree did not grow, for there was no grower.

Even Father did not see then as I do now.

The Grower had not come.

I had not come.

I am the Grower.

I failed.

And I think of myself as worthy? I am nothing—the failed child, of failed parents, of failed grandparents. How many generations must fail before we give up? Why do I try?

I have failed with the Tablet already. There are no second chances here.

And yet I long to hold it, and try once more.

Journal V



(Discovered near an elevator in the Great Shaft.)

Tomahna—my home—the place where I was: the place where I began. I was a spark of joy to Mother and Father, after their fire was almost quenched. And yet what joy could we have had if my brothers had been there as well?

Still torn.

Father and Mother loved and shared with me, their desert bird. Father shared wisdom and knowledge, and Mother shared visions and dreams.

Yeesha's Journals

When did they come to know my destiny? Surely not from birth. As I look back, they knew so much; they saw so clearly. They planted and watered, so that I would learn how to do the same. I would not realize it until long after I was to see them no longer.

Am I the Grower because they taught me, or did they teach me because I am the Grower?

Torn.

But peace was not yet with us. From the past, an enemy came, seeking revenge. But there was help for a third time. Without help, where would we be? Would there be a Grower? Would there be a seed to grow?

It's all been so fragile.

But it must be by the Maker I am here—and there is meaning.

Or it may be by the roll I am here—and there is no meaning.

Journal VI



(Discovered next to a glowing blue switch in an alcove off of the Great Shaft floor.)

I was very young when I first felt strong. Indeed, I was young, but I thought I understood. I had many abilities, even then, but little wisdom. Better to have fewer abilities and much wisdom.

I knew I was doing something great for us, but what I did was foolish for me. I thought I was reuniting our family, bringing back what joy we once had. I almost brought an end to life.

Yet again, it was a friend who came to our aid.

Now I think that most things cannot be returned to how they were. My brothers were not to be released. But the Maker turned my poor choice to some small good, and Achenar was redeemed.

My tears flow as I write these memories. The suffering and pain I have caused—and endured. And yet I am thankful. I will be powerful like the Bahro.

I long to be so strong.

They will sing a song of thankfulness. They will sing a song, without regard to their circumstances. They will stand and take time to sing to the Maker with hearts of joy. If only I could have such a heart.

Journal VII



(Discovered next to a generator in an alcove off of the elevated Great Shaft floor.)

Alone.

There is a powerful conjunction between the in and the out, the beneath and the above. A wound, a mouth, a well, a pit. I wanted to make the journey for myself from where the D'ni dug upward, where they almost came to the surface. From the place where Ti'ana first climbed downward, and where Father followed evil into the ground.

I began my journey with a heavy burden. It was Ti'ana who came to D'ni, and caused its fall. I am from her. I feel I am destined to bring another destruction.

Father and Mother tried to prepare me—tried to tell me who they thought I was. I still see the power of each. I have the best of each—and the burden of each.

Yeesha's Journals

And as they watched me leave, I saw the sadness and the fear. But more terrifying, I saw their hope.

And I left my comfort to find me. And even as I took my first step away from Tomahna, my shoulders ached, for the burden I bore. Deep prophecies and weighty destinies.

So much to learn and understand about myself. My father said we can never understand—we can only understand more.

The more I understood the more I powerful I became, and the more dangerous I became, and the less I understood.

Journal VIII

Home was far behind—I was no longer a child. I journeyed deep—deep within myself, deep within the earth, down to the D'ni cavern. I was alone for a time as I consumed my heritage, breathing deep the air of the cavern and the knowledge of my people.

But the desire for companionship drove me mad. I engaged a senomar as my confidant, and a tredfish in the harbor became my younger brother. I spoke to them as family and they answered, I swear they answered.

Then my mind took a final step into madness when I walked into the library on Ae'gura and saw an old D'ni man on the floor below me. Now I was imagining people to ease my loneliness.

But he was no mirage—his name was Calam. And he was a D'ni Writer of Ages.

Trust did not come easily. There was conflict between us—between his ancient rules of D'ni that I did not respect, and my creativity, which he feared. We fought and feared and battled and screamed, until exhausted, we began to learn from each other. We learned of the power of both, just as Father and Mother had done.



(Discovered next to a switch in the pit underneath the elevated Great Shaft floor.)

So I learned to Write with all the skills that the D'ni had known—beyond what my parents had taught me. For their lessons were given by a flawed instructor and by their own trial and error. I learned to Write from a Master: an opportunity Father was never given. Calam's abilities were breathtaking—he knew all the D'ni knew, when D'ni fell.

But I taught as well as learned. There were things that the D'ni were forbidden to Write, words they feared, concepts they shunned. Rules and boxes. I had no cultural fear of such things, so I dug deeper, asking questions that Calam could not answer. And together we sought answers.

That is how we learned of the Bahro and the Tablet. I learned of its power. We grew in knowledge and strength, and Calam became one of my dearest friends. I began to think that it was he who would be the Grower.

But evil will find you, even in the depths of the earth, and Calam was murdered.

Journal IX



(Discovered next to a door leading to the Great Shaft floor from a tunnel near the exhaust fan mechanism.)

Power is a gift. Power is a curse.

I learned of the fearsome power I wield on that day—the day of Calam's death. In a fit of rage I destroyed the murderer, and I destroyed my innocence.

And again I learned that most things cannot be returned to how they were.

And my power continued to grow even as I began to see that the prophecies of the Grower might speak of me. My destiny began to be fulfilled. But there was still more.

Yeesha's Journals

The Least. Abused. Mistreated. Misunderstood. Ignored. They were mocked and scorned and their hearts still show their pain, but they continue to serve.

Such power they have, and yet they serve. They treated me with kindness, and I learned from them. They respected what I was becoming. With them I learned new laws, new rules, and new powers. I used the powers to care for a tree to come, and the Tablet allowed me to grow beyond Ti'ana, beyond Father and Mother, beyond D'ni, beyond Calam.

The Tablet held them. The Tablet chained them.

The Tablet held me. The Tablet empowered me.

I watched with them. I waited with them. I learned with them. I called them from captivity and grew while they gathered. Together we became both weak and strong.

And then my time came. My time to take the Tablet. My time to choose. I was ready. I felt the pull of holding it, of channeling and releasing the full power of the Bahro. I would right the wrongs, I would set things the way they should be. I would choose well—I could not fail. I am the Grower.

I was so sure, so strong, so wise, but I didn't open myself and listen to the Maker. The noise of me drowned his quiet voice.

And I failed. Failed to see anything beyond myself and what was obvious. And pain came quickly, when I realized what I had done. The Tablet returned, and the Bahro continued to serve. The pain still burns me.

But the powerful Bahro simply wait and serve.

Pain is often how we learn. But it is not for us to give—we are not the teachers. We must not abuse them. We must not abuse the Bahro.



Journal X



(Discovered next to an inoperable door outside of the lowest rest area along The Descent.)

How could I have not seen the true path? I see it now so clearly. But can I get another chance to make things right?

They came. They came to D'ni—those who felt called. I knew they would. I was prepared for them, and I pointed the way. I spoke often of the pride of D'ni, of their belief in their own power and strength and the reason that D'ni once fell. And a few understand. And they begin to follow me. I am the Grower—I would lead them to rebuild.

Yet another burden.

But what is the task of a Grower? My father wrote another Age, but I see that the tree is not a place, but a people—the heart of a people. That is what must grow.

If only I had another chance to make things right. The Tablet is the key—how could I have failed?

Journal XI

I know what to do. I see it so clearly. One more chance to determine the destiny of the Tablet. I can feel it.

To be so close and yet be so powerless—it drives me mad. The Tablet sits there, holding the power of the Bahro captive, and I alone know what to do. I failed once, but what does that mean? Why am I punished when I could accomplish so much? The rules seem so arbitrary—some game of the Maker that only he understands.

Yeesha's Journals



(Discovered on a bunk in the lowest rest area along The Descent through the Great Shaft.)

This legacy of failure. And now I see this final chance to right generations of wrong. To unleash the power that has been held for thousands of years. It is at my fingertips. I know what must be done, but I cannot speak of it, for fear that it would somehow break the rules—tarnish the heart, taint the act, soil the innocence.

I had a dream...

I am carrying the seed of D'ni, the seed of all things that are D'ni, through a small cave. And I come to a place where the path stops, and there are two holes—one above me, and one below me. And through the hole below I can see the D'ni cavern and the great city. And through the hole above I can see the sky and sun.

A voice calls to me "In which hole will you plant the seed?"

And I know it is easy to drop the seed in the hole below, and I know it is impossible to throw the seed through the hole above. I call out to the voice, asking for wisdom.

And the voice answers me "Do not drop the seed in the hole below, for that is easy, but that is the way of the past. Do not throw the seed in the hole above, for that is difficult, and that is the task for another. In which hole will you plant the seed?"

And I know what to do.

And I know I am the Grower.

Quick Reference

Controls

There are three different control schemes to choose from in **Myst V**. Select the one that feels most comfortable for you.

Classic Mouse-Click Mode

To move forward in Classic Mouse-Click mode, position the cursor in the center of the screen so that the cursor becomes a finger pointing forward, and then click the mouse button. To turn right or left, position the cursor on the right or left edge of the screen so that the cursor becomes a finger pointing right or left, then click the mouse button. If the cursor is translucent, it means that no movement or interaction is possible.

To press a button or other object, position the cursor over the object so that it becomes a pointing hand, and then click the mouse button. To interact with a moving object, position the cursor over the object so that it becomes an open hand, and then click the mouse button to grasp the object and drag the mouse to move the object. Pressing **[1]** will switch you to this mode (Classic Mouse-Click).

In Classic Mouse-Click mode, when you click and hold down the mouse button, you move forward more quickly. To look around freely, hold down the right mouse button (or **control** + mouse button on a single-button mouse) and move the mouse to free-look. You can also click the mouse's middle button (if your mouse has one) to walk backward, but only if there is enough space.



Classic Plus Mode

Classic Plus mode has all of the functionality of Classic mode but allows for a greater freedom of view. In Classic Plus mode, your view is automatically locked to your cursor so your cursor stays in the center of the screen and your view changes as you move the mouse. Turn to look where you want to go and then click to move forward. To unlock your mouse from the screen, click the right mouse button (or **control** + mouse button on a single-button mouse). This is useful for accessing the menu items in the upper right of the screen, or the Slate when held in your hands at the bottom of the screen. Click the right mouse button (or **control** + mouse button) again to return to Classic Plus mode.

To press a button or other object, position the cursor over the object so that it becomes a pointing hand, and then click the mouse button. To interact with a moving object, position the cursor over the object so that it becomes an open hand, then click the mouse button to grasp the object, and drag the mouse to move the object.

In Classic Plus mode, you can also click the mouse's middle button (if your mouse has one) to walk backward, but only if there is enough space. Pressing **2** will switch you to this mode (Classic Plus).

Free-Move (Advanced) Mode

In Free-Move mode, **W**, **A**, **S**, and **D** are used as the default forward, left, backward, and right movement keys, respectively. The left mouse button moves you forward. Hold down **shift** while moving to run.

The cursor is locked in the center of the screen in Free-Move mode, but clicking the right mouse button (or **control** + mouse button on a single-button mouse) locks the view and allows you to move the cursor around the screen. This is useful for accessing the menu items in the upper right of the screen, or the Slate when held in your hands at the bottom of the screen. Click the right mouse button (or **control** + mouse button) again to return to Free-Move mode.

To access the journals and menu options, right-click/**control**-click to lock the screen, and then move the cursor to the screen's upper right corner. All of the Free-Move controls are fully customizable from the Controls Tab of the menu options. Pressing **3** will switch you to Free-Move (Advanced) mode.

Camera and Journals

The camera and three journals you acquire during your Quest can help you out immensely. Be sure you know the full capabilities of each.

Camera

You can find the camera on the floor next to a lantern in a hallway in K'veer at the start of the game. If you miss it, you can pick another one up on the floor next to a lantern at the beginning of your descent into D'ni.

To use the camera, unlock your mouse (either by right-clicking, **control**-clicking, or pressing **esc**) and click on the round camera icon in the screen's upper right. The snapshots you take with your camera are stored in your Player Journal.

Snapshots are not only good for remembering what you've seen along your journey, they also serve as game saves. To restore a saved game, open your Player Journal, turn to the appropriate snapshot and click "Restore Saved Game" above it.

Note

The game continually saves your progress. Restore a saved game from a snapshot only if you want to reset your game to an earlier point.

Player Journal

Find the Player Journal on the floor next to a lantern in a hallway in K'veer at the start of the game. If you miss it, you can pick another one up on the floor next to a lantern at the beginning of your descent into D'ni.

To use the Player Journal, unlock your mouse (either by right-clicking, **control**-clicking, or pressing **esc**) and click on the Player Journal icon in the screen's upper right. You can enter



Quick Reference

text in the Player Journal to remind you of what you've seen along your journey so far. The snapshots you take with your camera are automatically entered into your Player Journal.

Use the Player Journal to make notes about clues and puzzles you encounter, keep a list of tasks or objectives you need to complete, or simply record your observations as you travel through the Ages.

Encounter Journal

Whenever you encounter another character in **End of Ages**, everything that he or she says to you is recorded in your Encounter Journal, which you can refer back to at any time.

To use the Encounter Journal, unlock your mouse (either by right-clicking, **control**-clicking, or pressing **esc**) and click on the Encounter Journal icon in the screen's upper right. Click the corners of the pages to flip them.

Re-read the entries in the Encounter Journal throughout your journey. Not only do they often contain clues about what to do next, you will find that certain characters' words take on very different meanings as you progress through the Quest.

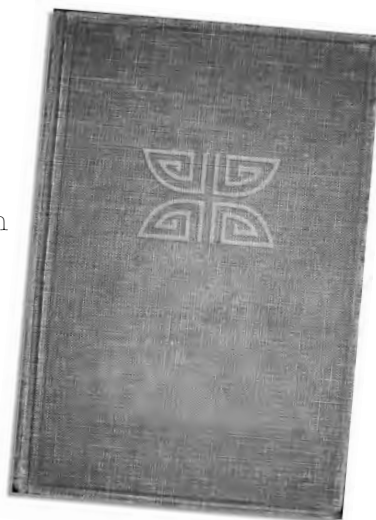

Yeesha Journals

Scattered throughout The Descent to D'ni are 12 Yeesha Journals, written by Yeesha and containing her reflections on the burden of D'ni that she and her family have had to carry. When you find one, click on it to pick it up.

To read the Yeesha Journals that you have collected, unlock your mouse (either by right-clicking, **control**-clicking, or pressing **esc**) and click on the Yeesha Journal icon in the



screen's upper right. A grid of Yeesha Journals appears on the screen. Click any journal to read it.

The Yeesha Journals are arranged in the grid in chronological order, with the upper left journal being the first one you find in your descent and the lower right one being the last one you find. If there is a gap in the grid, try backtracking through The Descent to see if you can find the missing journal.

Slates

In four of the Ages you journey through (Tahgira, Todelmer, Noloben, and Laki'ahn), you need to use a Slate to overcome the obstacles in your way. The relationship between the Slate and the Bahro is not fully understood.

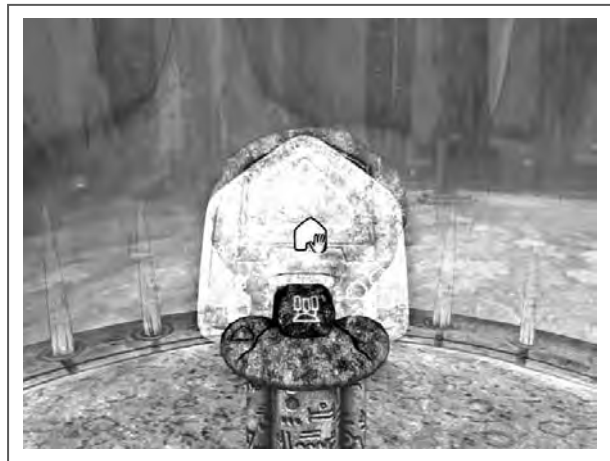

Slate Basics

To pick up a Slate, click on it when the cursor changes to a Slate icon. While a Slate is being carried, its top appears along the screen's bottom edge. Position the cursor over the top of the Slate and click to raise the Slate into position for writing on it. From this position, you can click anywhere on the screen except on the Slate to lower it again, or you can click along the bottom edge of the Slate to put it down on the ground. While carrying the Slate, you can also click on a pedestal to place the Slate on the pedestal.

To write on the Slate, click on its surface and hold down the mouse button while dragging the mouse. To erase what you have written, click on the "erase" icon on the Slate's lower left corner (the Slate outline with two lines drawn through it).

Quick Reference

Once you have inscribed a symbol on the Slate that has been understood by the Bahro, you can click the symbol's icon on the lower part of the Slate to quickly redraw it.

Using the Slate

Throughout the Ages, you will find glowing symbols. Draw these symbols on the Slate and leave the Slate on the ground for the Bahro to find. If you have drawn the symbol correctly, the Bahro will obey the command that the symbol represents.

When you come across glowing symbols on pedestals, draw the symbols on the Slate and leave the Slate on the ground. When the Bahro comes for the Slate, it will take the Slate to the pedestal that corresponds to the symbol that you drew on it. This also creates a link from the first pedestal in the Age to the pedestal that the Bahro brought the Slate to. You don't need the Bahro to bring the Slate to the pedestal to create the link, though. If you can physically reach the pedestal, place the Slate on the pedestal to create a link to that pedestal on the first pedestal in the Age.

Not all symbols are found on pedestals. Each Age has at least one symbol in it that causes the Bahro to produce some sort of global effect in the Age, from speeding up time to unleashing a torrential downpour. To use these symbols, inscribe them into the Slate, leave the Slate on the ground, and back away. When the Bahro appears and looks at the Slate, it will produce the corresponding effect. If you don't want the Bahro to reappear and link back to the first pedestal with the Slate, be sure to pick the Slate back up immediately after the effect begins. You usually have between 10 and 15 seconds to do so. The effects themselves generally last approximately 90 seconds.



Quick Reference Walkthrough

The following is a quick reference walkthrough, divided into three levels of detail:

Observations are for the dedicated player who just needs a little push in the right direction. They call your attention to details in each Age that you might want to pay a little more attention to, but they don't give explicit hints.

Suggestions are more detailed than observations, but they don't give away the actual solutions to the Ages' puzzles. If an observational hint isn't enough, try looking at the suggestion for the puzzle.

Solutions are written for the player who's completely stumped by a true brainteaser. They tell you exactly how to solve the puzzles in each Age. Some call this "cheating," but where's the fun in banging your head against a wall repeatedly?

Observations

K'veer



The locked Myst Linking Book

Myst Book: In the K'veer room you begin the game in, there is a Linking Book to Myst sitting on a table. This is Atrus's Myst Linking Book, last seen in **Myst** and **Riven**.

Exiting K'veer Prison: The room you start the game in is the same room that served as Atrus's prison in **Myst**. But there must be a way out of it, or this is going to be a very short Quest!

The Tablet: The Tablet sits glowing in a stone contraption. When you pass your hand over it, the Tablet becomes solid, but it changes back again when you move your hand away.

Quick Reference

The Volcano

Finding “The Hole in the Ground”: The desert sun is scorching. There's got to be somewhere you can go to get away from it.

The Descent to D'ni

Rest Areas: After finding your way into the hole in the ground, you find your first rest area down the corridor to the right.

Descending the Great Shaft: The Great Shaft is a massive vertical shaft that links the deep city of D'ni to the surface world. Catwalks run along the perimeter, but most of them are in no condition to bear any weight.

Great Shaft Floor: After riding the Great Shaft elevators down to the floor of the Great Shaft, there doesn't seem to be any way to reach Direbo and proceed to the next Age. There is a doorway across the Great Shaft from the bottom of the second elevator, but there is no way to reach it.

Activating the Exhaust Fans: Esher said: "You will not be able to continue downward without providing fresh air to the tunnels. Raise this floor and power the fans."

Direbo

Bridges: Four bridges span the four islands in Direbo.

Bubbles: Each of Direbo's four islands has a translucent bubble on it. Inside the bubble is a pedestal and a Slate.

Linking Books: Each of Direbo's four islands has a pedestal on it. On each pedestal is a Linking Book.



Concept art of Direbo

Tahgira

The Cave: Esher said something about freeing yourself from the room and being grateful for the weight of your burden. There's something drawn on the floor.

The Ladder: The Slate cannot be carried on ladders, but your goal is to move it through the Age to an end point. There must be another way to get it up the ladder.

Crossing the Water: The icy slope on the other side of the pool of water is too slippery to climb up. A grid of pipes spans the bottom of the pool of water, and each submerged pipe is lined with vents. The pipes run up to two pipe junctions, which are connected to six large engines around the village.

The Keep: When you approach the Keep, it moves away from you. Esher implied that something like this would happen, and told you to "make them [the Bahro] bring you to the Keep."

Todelmer

Concept art of the tram in Todelmer

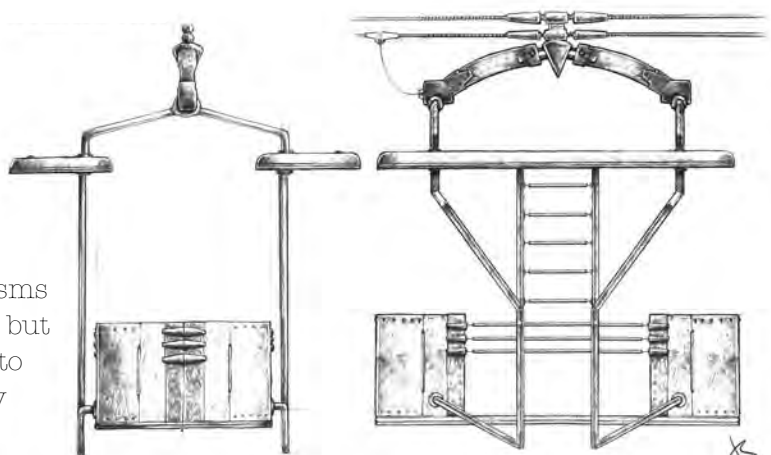

Power: There are a number of mechanisms in the control room, but none of them seem to be supplied with any power.

Crossing Over: The cable from a wrecked pulley blocks the upward path to the top of the first pillar. You can't continue climbing until you find a way past it.

Pillar 2: The small telescope on top of the first pillar gives you a great view of most of the rest of Todelmer, but the large spool near the telescope obscures your view of some of the pillars.

Quick Reference

Pillar 3: Your view of the next pedestal through the second pillar's small telescope is obscured by huge mechanisms. They look like large telescopes.

The Keep: There doesn't seem to be anywhere else to go in Todelmer, and the Keep is nowhere to be found. Esher mentioned that your destination is "not here, but above," that the "stars and planets must be aligned," and that only the Bahro were capable of such a thing.

Noloben

Dais under a Canopy: There's a dais under a canopy on the beach near the starting position with four bowls surrounding an egg-shaped rock. Various primitive symbols are carved into the stone wall behind the dais, and a glowing symbol is etched into the base of the dais. What could it all mean?

Windows in the Dome: The grassy plateau above the main island has a huge egg-shaped dome in the center of it. Each of the 15 windows in the dome has a symbol engraved above it.

Tunnels: One of the two tunnels on the beach dead-ends at a smooth stone wall, which blocks your path completely.

Opening Doors: It seems as if the rotating stones on the plateau above the island are somehow related to the sealed doors in the tunnel below the plateau.

The Keep: There is a door set into Noloben's smaller island. There must be something important behind it, but how is it opened?

Laki'ahn

Concept art of Laki'ahn

Windmill: There is a windmill outside of a holding pen, but there isn't enough wind in the Age to power it.



Arena Elevator: The third pedestal is on an elevator in the arena stands. The elevator seems to work on a counterweight mechanism and needs to be balanced properly in order to be used.

Trade House: The jeweler's door to the trade house is locked, but Esher said it could be unlocked.

Fighter Maze, First Floor: You must use an elevator in the first floor of the fighter maze to reach the second floor. There's a lever and a pressure plate near the elevator.

Fighter Maze, Second Floor: From the top of the fighter maze elevator, there are four corridors you can go down. Two of them have red switches at the end of them. One has a green switch, and one has a blue switch.

Fighter Hut: A crudely constructed hut is on a hidden beach beyond the fighter maze, but there doesn't seem to be any obvious way of entering it. Seven boulders hang from ropes next to it.

The Keep: Looking through a window in the fighter hut, you can see a distant island. Could there be a way to get there?

End of Game

Concept art of
the Tablet



ROSETTA TABLET

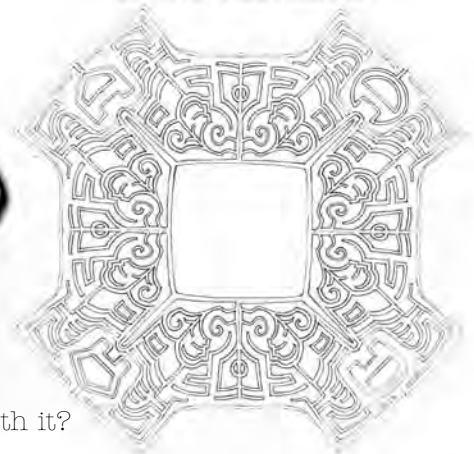

ROSETTA TABLET CARVING

Who Will You

Choose?: All four stone locks on the Keep have been released. You can now take the Tablet...but what will you do with it?

Yeesha: When you pick up the Tablet from the Keep, Yeesha appears in K'veer and holds her hands out to you.

Esher: Esher has unlocked the Myst Linking Book in K'veer, where you began your Quest. You can link to Myst with the Tablet if you wish.

A Third Option?: Esher and Yeesha both tell you not to give the Tablet to Yeesha. But if you don't want to bring the Tablet to Myst as Esher suggests, what option does that leave you?

Suggestions

K'veer

Myst Book: The Myst Linking Book is bound securely with leather straps and a complex locking mechanism. There doesn't seem to be any way to unlock it.

Exiting K'veer Prison: There is a Myst Linking Book in the room, but it appears to be securely locked. Nothing you can do will unlock the Linking Book at this time.

The Tablet: Touch the Tablet to solidify it and begin your Quest. Exit the bubble and Yeesha will meet you. The Tablet is held securely by four heavy, immovable stone locks. The four stone locks are shaped like four objects you will see in the Ages you visit in your Quest. They resemble the four Slate pedestals in Tahgira, Todelmer, Noloben, and Laki'ahn.

The Volcano

Finding "The Hole in the Ground": Esher mentioned something about "where your journey begins." He told you to "look for the hole in the ground."



Concept art of the volcano

The Descent to D'ni

Rest Areas: There is a linking book to Direbo in each of the rest areas. Notice the diagrams drawn on each book and where that book takes you. There are four rest areas in The Descent, each taking you to one of four islands in Direbo.

Descending the Great Shaft: You can't walk to the bottom of the Great Shaft, but fortunately there are elevators that run up and down along it. Unfortunately, the elevator cars aren't at the level that you're on.

Great Shaft Floor: If you enter the alcoves at the bottom of the Great Shaft, you find two buttons, one blue and one yellow. Pressing these buttons begins a timing device. There is also a red button in the middle of the Great Shaft floor. This red button illuminates after you press the blue and yellow buttons.

Activating the Exhaust Fans: If you elevate the Great Shaft floor and ride it upward, you cannot descend the alcove stairs to return to the bottom of the Great Shaft, which means you can't explore below it to find the exhaust fan mechanism.

Direbo

Concept art of Direbo's bridges

Bridges: Each bridge has two locked gates, one at each end. Each locking mechanism is extremely simple and can be unlocked by anyone standing on one of the four islands and facing the gate.

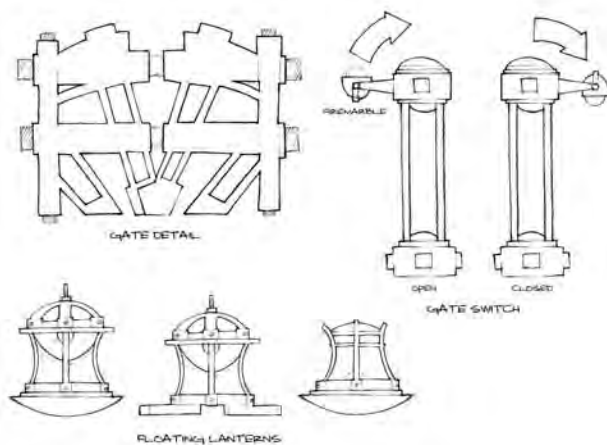

Bubbles: Standing inside of a bubble allows you to see scenes of another Age projected on the inside of the bubble. This is the view of the Age that the bubble's pedestal links to. The bubbles exist simultaneously in Direbo and in the four Ages.

Linking Books: The Linking Panel on each Linking Book gives you a glimpse of one of the D'ni rest areas along the Great Shaft. Because the rest areas are so similar in appearance, it's hard to tell which Linking Book leads to which rest area, but there are diagrams drawn on the books to assist you.

Quick Reference

Tahgira

Concept art of Taghira

The Cave: A crack on the floor makes a cracking noise every time you walk across it. Your weight with the Slate's is not heavy enough. You need something heavier to stand there. Esher said, "They will take it, if you drop it. They will obey it, if you order them. They will return it, in time."



The Ladder: On the face of the pedestal atop the ladder there is a symbol that can be drawn on the Slate. What did Esher say about ordering and obeying?

Crossing the Water: Each of the six thermal engines has a valve switch that can be opened or closed. The pipe junctions have three control switches that direct the engines' heat to the pipes under the water pool, but they are inaccessible. Perhaps the Bahro could help you with them? And what is the purpose of the map inside the central hut in the village?

The Keep: Although you can't reach the Keep, you can see the Keep's pedestal symbol.

Todelmer

Power: There is more to the control room than just the four control panels and the vertical measuring device. Perhaps the rear of the room holds something of interest?

Crossing Over: There are other similar pulleys visible on the first pillar. In fact, there are four pillars in total, one of which is broken. By coincidence, there are also four control panels in the control room, one of which can't get reception.

Pillar 2: If you look carefully at one of the obscured pillars, you can see something that looks like a pedestal on it. The large spool is part of the tram mechanism. If you could move it, you might be able to get a better view of the distant pillar beyond it.

Pillar 3: The large telescopes are controlled via the machinery in the control room, but you need to know the proper coordinates for the large telescopes. The small telescopes on the first and second pillars let you see two sets of coordinates etched into the base of distant pillars.

The Keep: Riding the tram from the third pillar to the first gives you a glimpse of a third set of telescope coordinates and another symbol, which looks like a ringed planet. To ride the tram, you must make sure it is parked at the third pillar's tram station. If it is not, return to the first pillar's tram controls, move the top lever to the left, and pull down on the middle lever to park the tram at the third pillar's dock. Link back to the third pillar, climb down the stairs next to the third pedestal, and then climb down into the tram. You must also restore power to the tram before you can ride it, so walk up the stairs beyond the tram to find a power control panel similar to the one in the control room. Once again, make the dim blue globe glow as brightly as possible by setting the right lever to its middle position and moving the left lever two-thirds of the way up. Return to the tram and push the lever in the middle of it forward to start the tram moving forward. It pauses between the third and first pillar, and the coordinates and planet symbol are etched into some machinery directly outside of the tram.

Noloben

Concept art of Noloben

Dais under a Canopy: It looks as if the rock and bowls all have "shadows" engraved into the dais. There are also four holes cut into the canopy, one above each bowl. And take a closer look at the shape of the slab that the glowing symbol is etched



Quick Reference

into. It's an upside-down version of the Slate found at the first pedestal in this Age.

Windows in the Dome: The dome's windows can be opened and closed. Looking through the dome's windows, you see that each window also has a symbol engraved above it on the interior wall. These symbols are similar to the ones reflected in the water bowls on the beach.

Tunnels: The obstructing stone is too smooth to be a naturally occurring formation. It must be a part of some kind of mechanism. It seems to be the same type of stone as the four smaller rotating stones on the plateau above the tunnel.

Opening Doors: The arrangement of the dome and rotating stones on the plateau resemble something else you have seen in this Age (the stone and bowls on the beach). The rotating tops of each of the stones have symbols on them. These symbols are from a different set than the ones seen in the reflecting bowls on the beach. The sun does not seem to move in this Age, meaning that the shadows cast by every solid object in the Age do not move either.

The Keep: There is an illustration of a tree on the floor of an observation post at the top of the plateau dome. You can reach this post only by closing at least one of the tunnel doors to the laboratory and linking into Esher's laboratory by using the first pedestal's link to the second pedestal. Climb the ladder at the top of the laboratory to reach it. Whenever you or any other living creature stands on the tree, the small island door opens, but the door closes as soon as you step off. Esher also mentioned that the Bahro are terrified of snakes, and even the image of a snake will keep them away.

Laki'ahn

Windmill: Cables from the windmill appear to be connected to the holding pen in front of it. It looks as if the second pedestal is submerged in the center of the holding pen. Near the windmill is a boneyard, and on the wall of the boneyard is a glowing symbol that orders the Bahro to create a gale force wind. However, simply having wind doesn't seem to be enough to power the control panel inside the windmill.

Arena Elevator: A scale near the elevator weighs whatever is placed on it. The number of markers next to each circular symbol indicates how many units of that weight are on the scale. Each circle in a symbol means one unit of weight (e.g.: the four-circle symbol is four weight units).

Trade House: Five geometric shapes span the length of the door lock. They look like the same shapes on the scrap of paper that can be seen through the trade house windows near the link-in point for the Age.

Fighter Maze, First Floor: Raising the lever to its highest position "primes" the counterweight for the elevator. You may have to lift the lever repeatedly to move it all the way up. Standing on the pressure plate triggers the counterweight and raises the elevator as long as there is weight on the pressure plate. You can't stand on the pressure plate and the elevator simultaneously, though.

Fighter Maze, Second Floor: If you explored the trade house carefully, you found a helpful clue for this puzzle: a scrap of paper with the colors red, red, green, and blue on it.

Fighter Hut: Walking around the rear of the hut brings you to a locked entrance. The boulders seem to be connected to the locked entrance as part of a primitive counterweight lock.

The Keep: A flag hangs from the same window. There's something written on the flag, but you can't tell what it is. If the air wasn't so still, you might be able to make out the flag's insignia....

End of Game

Who Will You Choose?: Both Yeesha and Esher have said that the Tablet contains the full power of the Bahro. They have also both told you not to give the Tablet to Yeesha.

Yeesha: If you approach Yeesha and click on her while holding the Tablet, you can give Yeesha the Tablet. However, both Esher and Yeesha have warned you against doing so.

Esher: According to Esher, Yeesha views Myst as a cursed Age and will not travel there. If you want to prevent her from getting the Tablet, taking it to Myst will do it.

Quick Reference

A Third Option?: Considering his history with the Bahro and his contempt for them, Esher might not be the best source of advice for what to do with the Tablet. Also, if you link to Myst, you might not have a way to return from there. Is Yeesha really holding out her hands to you asking for the Slate, or does her gesture suggest something else?

Solutions

K'veer

Concept art of the Keep

Myst Book: You cannot use the Myst Linking Book at the start of the game. It doesn't become available to you until you have released the four stone locks on the Keep from the Tablet.

Exiting K'veer Prison: Examine each of the doors carefully. One of them has a handle that you can turn to open the door and proceed.

The Tablet: To unlock the Tablet, you must reach the Keep in each of the four Ages you visit. Once you reach the Keep in each Age, you must place the Age's Slate on the pedestal and touch the Slate in order to release the Tablet lock.

The Volcano

Finding "The Hole in the Ground": Look around the area and you'll find a nearby cleft in the ground you can fit in (not the porous rock of the steam vents). Climb down into it via the rope ladder attached to it to begin your descent into D'ni.

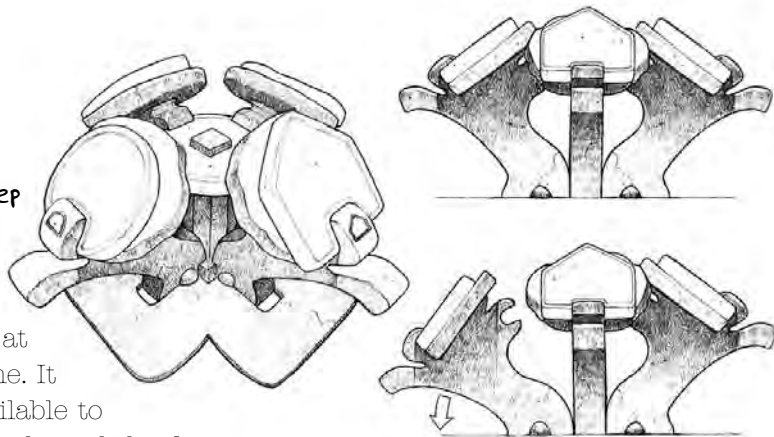

The Descent to D'ni

Rest Areas: When you go to an island, unlock the gates on the bridge to create a shortcut between the islands. Otherwise you'd have to go back and around through The Descent to another rest area.

Descending the Great Shaft:

Pull the lever to the left of an elevator to call a car. Step into the elevator and pull the hanging cord to ride it down to the next level. You can also pull the cord again to return to the level you just came from. Riding the elevators down leads you to a D'ni rest area that contains a Linking Book to an island in Direbo. The rest area is on the level at the bottom of the first elevator ride.



Rest area Linking Book to Direbo

Great Shaft Floor: Press either the blue or yellow button. Run across the bottom of the Great Shaft floor to the other alcove and press the other button. Return to the center of the Great Shaft floor and press the red button. The floor starts to rise after a short delay. Ride the floor all the way up and go through the previously inaccessible doorway across the Great Shaft from the bottom of the second elevator. There, you will find a D'ni rest area and a Linking Book to the next island in Direbo. The rest area is on the level at the bottom of the second elevator ride.

Activating the Exhaust Fans: Raise the Great Shaft floor as described previously, but after pressing the red button, run to the outer edge of the room to send the floor up without you on it. Descend the ladder into the pit under the floor to find a tunnel leading to a switch. Pull the switch to start the exhaust fan and drop a ladder from the ceiling of the tunnel. Climb the ladder to reach a hub area. Go through the open doorway in the hub area to reach a D'ni rest area and find a Linking Book to the final island in Direbo.

Quick Reference

Direbo

Concept art of a Direbo Linking Book pedestal

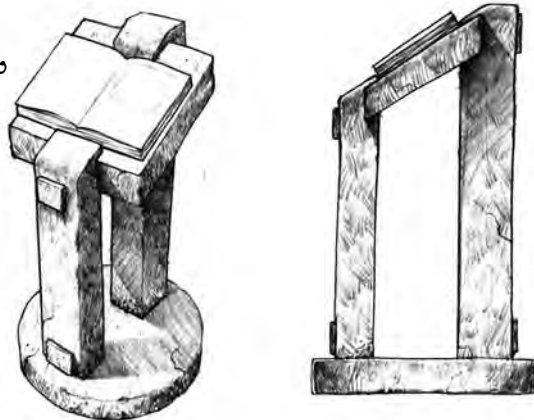

Bridges: You can't unlock a gate while standing on the bridge side of it. You can only unlock them from the island side. As you visit each of Direbo's four islands via the Linking Books in the D'ni rest areas, be sure to unlock both gate locks on the island to create shortcuts between the islands.

Bubbles: The pedestal in the center of each bubble contains a link to an Age. Touch the glowing symbol shaped like the Age's Slate to link to that Age.

Linking Books: Each Linking Book takes you back to one rest area along The Descent to D'ni. Touch the Linking Panel to link to that rest area.

Tahgira

The Cave: Drop the Slate on the crack area and back away until the Bahro creature comes to take it. Retrieve the Slate from the Take pedestal after the Bahro returns it, and stand on the broken ice with it to break through.

The Ladder: Drop the Slate at the bottom of the ladder and climb up to view the pedestal there. The Bahro takes your Slate back to its last pedestal, in this case the Take pedestal at the beginning. Use the pedestal to link back to the Take pedestal in the cave, and draw the symbol on the Slate that's the same as the pedestal you want the Bahro to take it to, put it on the ground and step away. The Bahro will take the Slate to the first pedestal.

Crossing the Water: Turn all six of the thermal engines' switches to the right to open their valves. Use the Bahro "heat" command on the Slate to raise the core temperature of the Age and activate the junctions' control switches. Refer to the map inside the hut in the center of the village to set the junctions' control switches and create a pathway across the pool of water. From left to right, set the blue junction's switches right, left, left; set the red junction's switches left, right, left.

The Keep: Draw the Keep's pedestal symbol on the Slate. Drop the Slate and back away from it. A Bahro appears and brings the Slate to the Keep. Return to the first pedestal at the beginning of the Age and use it to link to the Keep. Touch the shimmering Slate on the Keep to solidify it and complete the Tahgira portion on your Quest, then link back to Direbo from Tahgira's first pedestal.

Todelmer

Concept art of Todelmer

Power: Approach the dim blue globe at the rear of the room and manipulate its horizontal and vertical switches to restore power to the control room. The trick is to illuminate the blue globe as brightly as possible. Set the left lever to its middle position and the right lever all the way to the right.



Crossing Over: The pulleys are controlled via the mechanisms in the control room. Restore power to the control room, and then use the broken control panel (the rear right panel as you look into the room from the doorway) to retract the broken cable and clear the path. Push the control panel's vertical slider all the way up and press the flashing green button to retract the cable.

Pillar 2: Enter the tram house at the top of the first pillar. Close the door from inside and press the glowing button behind the door to reveal a hidden staircase. Descend the tram house stairs to reach the tram controls. Use the tram controls to rotate the large spool slightly; keep the top lever in its rightmost position and pull the middle lever down once to rotate the spool. Return to the small telescope and take another look. The symbol for the second pedestal is clearly visible. Draw it on the Slate, put the Slate on the ground and wait for the Bahro to collect it and take it to the second pedestal. Return to the first pedestal and use it to link to the second pedestal.

Pillar 3: Return to the control room by linking from the second pedestal and enter the proper coordinates into the control panels. The set of coordinates seen from the first pillar's small telescope is for the front right control panel (as you face it from the doorway). The set of

Quick Reference

coordinates seen from the second pillar's small telescope is for the front left control panel. Return to the second pedestal by linking from the first pedestal and look at the two large telescopes through the small telescope to see the third pedestal. Draw its symbol onto the Slate, put the Slate down, back away and let the Bahro take it to the third pedestal, thus creating a link from the first pedestal to the third.

The Keep: Inside the third pillar's tram house is another symbol that causes time to speed up when it is etched onto the Slate and the Slate is laid on the ground for the Bahro to recover. To access the tram house, climb up the stairs leading from the tram dock and open the tram door (you must have restored power to the third pillar in order to do this). Return to the control room on the first pillar and enter the third set of telescope coordinates into the rear left control panel. Use the "time" symbol to speed up time so that the angle of the ring around the large planet in the sky matches the angle of the ring on the planetary symbol above the third set of coordinates. Unless you have spent an uncommonly long time in this Age, you need to use the "time" symbol twice to move the ring into proper position. Press the zoom buttons above the control panel's monitor to see the Keep symbol. Etch the symbol onto the Slate, leave the Slate for the Bahro to pick up, and then link from the first pedestal to the Keep. Touch the translucent Slate in the Keep to complete the Todelmer portion of the Quest.

Noloben

Dais under a Canopy: The glowing symbol on the slab is upside-down. Draw the glowing symbol right side up on the Slate and leave the Slate for the Bahro to recover. The Bahro causes a heavy rain to fall for 90 seconds, filling up the stone bowls under the canopy holes. When the rain stops, stand directly in front of the dais and look at the bowls. Make a note of the symbols reflected in the water and the shapes of the

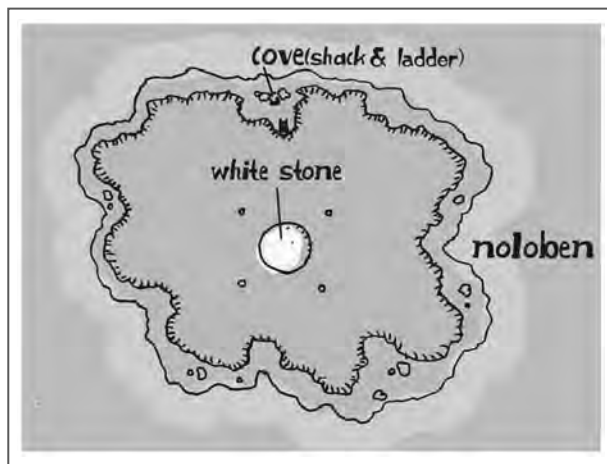

Concept map art of Noloben

shadows engraved into the dais. These are important clues for the translation puzzle. After a little while, the water drains from the bowls. Use the "rain" symbol again if you need to fill them up again.

Windows in the Dome: The symbols above each window on the interior of the dome translate to the symbols above the same windows on the exterior of the dome. Look through the dome's windows at the interior symbols and find the four symbols that you saw reflected in the bowls on the beach. Translate the four bowls' symbols to their corresponding dome exterior symbols.

Tunnels: The rotating stones on the plateau open and close doors through the tunnel below. To open the doors through the tunnel and reach Esher's laboratory, you must set all four rotating stones on the plateau to their proper positions.

Opening Doors: Figure out which rotating stones correspond to which reflecting bowls by matching the shadows cast by the stones and the "shadows" engraved into the dais on the beach. Rotate the stones' tops so that they are set to the correct symbols (i.e.: the ones that translate to the symbols seen in the bowls on the beach). Doing so opens the four doors in the tunnel below the plateau and gives you access to Esher's laboratory.

The Keep: Draw the "snake" symbol on the Slate and place the Slate on the tree symbol. Quickly link back to the first pedestal and run through the tunnel that leads to the small island. You can reach the small island by crossing a narrow strip of shallow water. The Bahro will come for the Slate as soon as the "snake" symbol fades from it. When the Bahro stands on the tree symbol to pick up the Slate, the small island door opens, allowing you entrance to the Keep. Make a note of the Keep's symbol, return to the Slate on the first pedestal, draw the Keep's symbol on the Slate and leave the Slate on the ground for the Bahro to recover. Link to the Keep from the first pedestal and touch the translucent Slate to complete the Nloben portion of your Quest.

Laki'ahn

Concept art of Laki'ahn

Windmill: Use the "wind" symbol to summon a gale by drawing the symbol on the Slate and leaving the Slate on the ground for the Bahro



Quick Reference

to find. Step into the windmill's control panel and pull the left lever to power up the windmill. Once the windmill is powered up, pull the middle lever once to elevate the cylindrical cage in the center of the holding pen. Make a note of the second pedestal's symbol in the cage for future reference. Rotate the cylindrical cage so that its opening faces the stream that leads to the arena by pulling the right lever twice. Open the cage gate to the stream by pressing the left button. Draw the pedestal's symbol on the Slate and leave the Slate for the Bahro to recover. Link from the first pedestal to the second and then proceed down the stream and into the arena.

Arena Elevator: The four buttons behind the elevator control the counterweight for the elevator. Once the counterweight is entered, pressing the large gold button sets the counterweight. You need to set the counterweight so that you can link onto the elevator and have it sink so that it is exactly even with the footbridge to the arena's second level. You weigh six units. The Slate weighs one. The pedestal itself weighs nine units. Set the counterweight to 16 units and link onto the elevator.

Trade House: When you look through the trade house window to see the paper with the combination, you're looking at the paper upside-down, so be sure to take that into account before entering the combination. Touch the symbols on the lock in the correct order to open the door. The order is: circle, square, triangle, hexagon, and diamond.

Fighter Maze, First Floor: Erase all markings from the Slate and place the Slate on the pressure plate. Prime the counterweight, and then step on the elevator. When the Bahro comes for the Slate, its weight triggers the counterweight and sends you up toward the second floor of the fighter maze. However, the Bahro also links away too quickly for the elevator to rise all the way up, so you need to inscribe the "sing" symbol on the Slate (found in one of Yeesha's journals) in order to keep the Bahro on the pressure plate long enough for you to reach the second floor.

Fighter Maze, Second Floor: Go down one of the corridors with a red switch at the end of it. Press the switch, and then continue down one of the forks in the corridor that has another red switch at the end of it; press this switch. Continue down the corridor, pressing the correct switches at each junction. Although there are two pathways that start with a red switch, only one path has all four switches in order (red, red,

green, blue). If you choose the wrong path, return to the elevator and start over. The final switch opens a door that leads outside to the fighter hut.

Fighter Hut: Open the door by properly balancing the counterweight mechanism. Pulling a cord next to a boulder raises the boulder and adds it to the counterweight. Raise one large, one medium-sized, and two small boulders to open the locked door. Proceed through the door and into the hut.

The Keep: Use the "wind" symbol to kick up a gale and reveal the Keep symbol on the flag. Draw the Keep symbol on the Slate and leave the Slate for the Bahro to recover. Return to the pedestal outside of the fighter maze and link to the first pedestal, and then link from the first pedestal to the Keep. Touch the translucent Slate in the Keep to complete the Laki'ahn portion of your Quest.

End of Game

Who Will You Choose?: You can take Esher's advice and bring the Tablet to Myst, where Yeesha will not follow. To do this, use the now unlocked Linking Book in K'veer. You can also give the Tablet to Yeesha when she holds her hands out for it. To do this, click on Yeesha while holding the Tablet. There is also a third option: You can put the Tablet on the ground and back away from it, letting the Bahro take their Tablet back.



Yeesha, Esher. . . or a third option?

Yeesha: Yeesha has already completed this Quest, and her goals have not been fulfilled. Giving her the Tablet will only cause you to fail your own Quest.

Esher: Link to Myst with the Tablet and place it on the pedestal in the library if you want to take Esher's advice. But Esher has his own plans for the Tablet, plans that will doom the Bahro to further servitude, and those plans don't include linking you away from Myst. If you leave the Tablet on Myst, Esher will take it and leave you to rot on Atrus's abandoned Age.

A Third Option?: If the Tablet is a Bahro artifact, why not give it back to the Bahro? Place it on the ground and back away from it, and the Least will reclaim their Tablet, resulting in a successful completion of your Quest.

The **Myst** Mythos

Myst Chronology

Over the course of a dozen years, Rand Miller and his team of "Cyantists" at Cyan Worlds have told the story of the rise, fall, and rebirth of the D'ni people. With the release of **Myst V: End of Ages**, the story has finally come to an end. In honor of the story that spans hundreds of years and has captured the imaginations of millions of fans, we present this retrospective look at the **Myst** mythos.

Myst: The Book of Ti'ana

Published in 1996 as the second of three **Myst** novels, the events in **The Book of Ti'ana** are based on the journals of Atrus's wife Catherine. In terms of the **Myst** storyline, **Ti'ana** is set approximately 250 years in the past.

The Book of Ti'ana tells the story of how Atrus's human grandmother, Anna (**Ti'ana** in D'ni) discovers the city of D'ni and becomes a part of its culture. Initially, she is shunned as an outsider, but she proceeds to earn full legal D'ni citizenship, if not acceptance from all of the D'ni people.

During Anna's time in D'ni, she meets, falls in love with, and marries a D'ni man named Aitrus, Atrus's grandfather. Despite Anna's being human and Aitrus D'ni, they manage to have a son, Gehn.

The Book of Ti'ana ends with the fall of the city of D'ni and its people. Two disgraced D'ni noblemen, Veovis and A'gaeris, spread a plague that kills

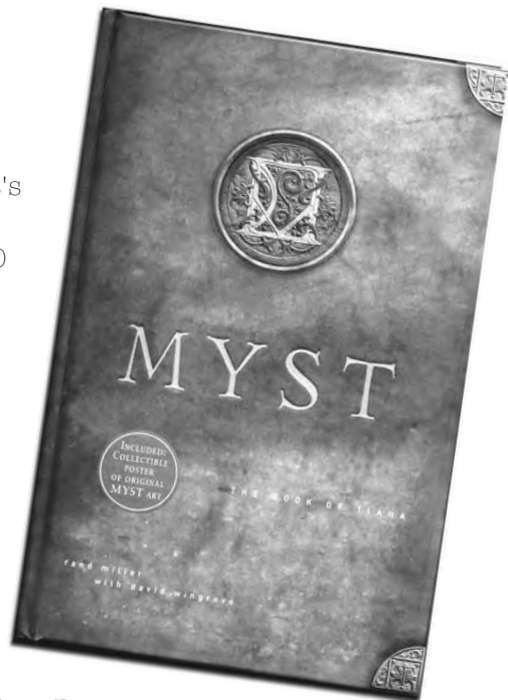

most of the D'ni and forces the rest to flee through Linking Books, scattering their people across hundreds of Ages. Because Anna had pleaded with the D'ni Council to spare Veovis's life some years prior, there are some surviving D'ni, including her son Gehn, who blame her for D'ni's fall.

Myst: The Book of Atrus

The Book of Atrus was published in 1995 and is the first of the three **Myst** novels. Like the other two **Myst** novels, it is based upon the journals of Atrus's wife, Catherine. Although it was published before **The Book of Ti'ana** and after **Myst**, the events in **Atrus** take place after **Ti'ana** and before **Myst**, approximately 200 to 250 years ago.

The Book of Atrus is, as the title suggests, the story of Atrus, the central figure of the **Myst** mythos. Raised by his grandmother, Anna, in a desert Cleft in what would eventually be known as New Mexico, Atrus is initially almost completely unaware of the existence of D'ni. However, his estranged father, Gehn, returns to collect the adolescent Atrus and bring him down to D'ni, the great cavernous city lying deep beneath the desert Cleft. In D'ni, Gehn teaches Atrus the Art of Writing Linking Books and attempts to reconnect the boy to his D'ni heritage in the dead city.

Atrus soon realizes that Gehn lacks the discipline and restraint instilled in the D'ni Writers because Gehn believes himself to be a god over the Ages he links to. Atrus reveals Gehn as a fraud and traps him in Riven, one of Gehn's own Ages. Atrus retires to the Age known as **Myst** with Catherine, his wife whom he met on Riven, and his grandmother, Anna.

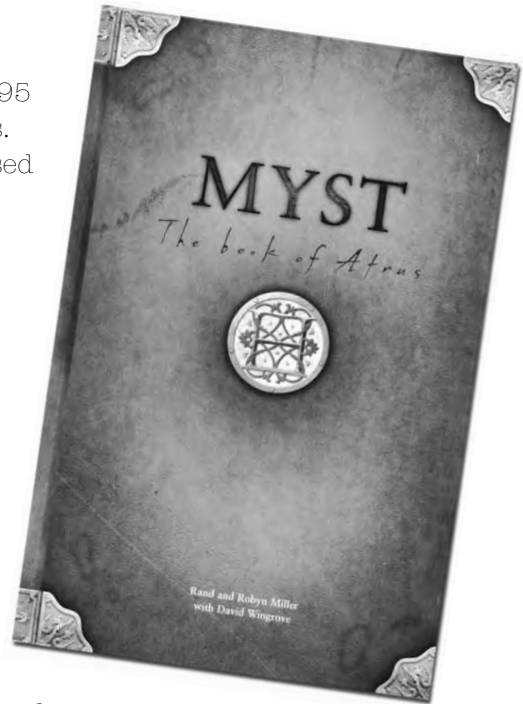

The **Myst** Mythos

Myst

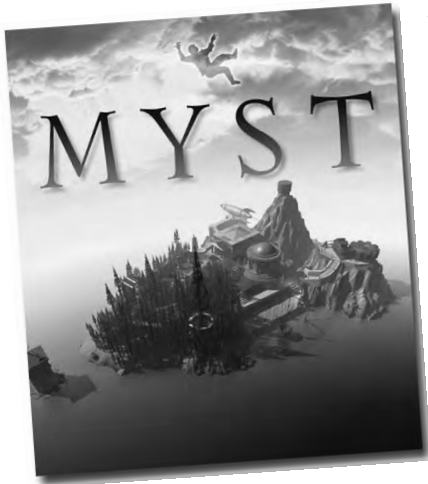

Developed by Cyan and published by Broderbund Software (PC and Mac versions) and Sunsoft (all other versions) in 1993, **Myst** was the first glimpse into the world of the D'ni. For story purposes, **Myst**'s story is based on events from 200 years ago that were recorded in Catherine and Atrus's journals. According to the overarching **Myst** mythos, Rand and Robyn Miller actually journeyed down to D'ni with Dr. Richard Watson prior to making the game.

Note

Myst was rereleased as Myst Masterpiece Edition in 1995 and again as realMYST in 2000. Masterpiece and realMYST's storylines are identical to the original Myst's.

Myst begins at the exact moment that **The Book of Atrus** ends, with the Linking Book to **Myst** falling through a starry fissure and landing at the player's feet.

During the course of **Myst**, the player discovers the unsavory history of Atrus and Catherine's sons, Sirrus and Achenar. Although Atrus never taught them to Write Ages, the brothers did have access to their father's library of Linking Books, and they ruled over the inhabitants of the Ages with an iron fist, much as did their grandfather, Gehn. Upon discovering his sons' betrayal, Atrus imprisoned them inside Linking Books, removed six pages from each Linking Book, and scattered the pages around various Ages.

Atrus himself is trapped in D'ni because a single page is missing from his *Myst* Linking Book. When the player restores that single page, Atrus is freed. He destroys his sons' Linking Books, trapping them in their Prison Ages, and tells the player that his wife, Catherine, is being held hostage in another Age. Atrus returns to his writing but tells the player that he might need help in the future to free his wife from the clutches of his unnamed foe.

Riven

Riven was the second *Myst* game that Cyan developed; it was published in 1997 by a host of companies (Acclaim, RedOrb, Sunsoft, and Broderbund). Like *Myst*, the events of **Riven** were based directly on Atrus's and Catherine's journals, events that took place almost immediately after *Myst* (approximately 200 years ago).

At the start of **Riven**, Atrus's wife, Catherine, is being held hostage in her home Age of Riven by his father (and her former fiancé), Gehn. Riven was the fifth Age that Gehn wrote, and like all of Gehn's Ages, it is geologically unstable. Atrus must remain in D'ni and continue making subtle corrections to Riven long enough for the player to rescue Catherine.

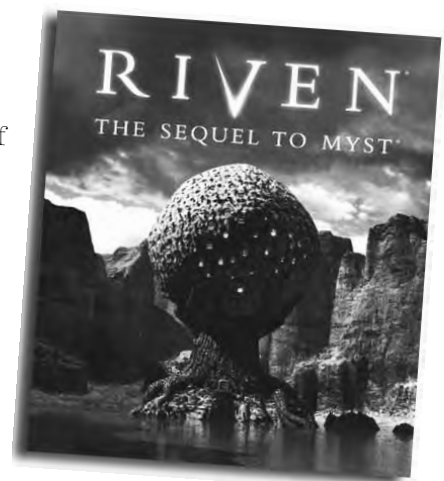

The player goes to Riven with a trapped Linking Book that appears to contain a link back to D'ni. Near the end of the game, the player is captured by Gehn, who makes the predictable mistake of assuming that the trapped book is supposed to be the player's means of returning to D'ni. Gehn uses the Linking Book and traps himself in a Prison Age.

The player then rescues Catherine, who leads her people to safety in the Moaiety Age that she wrote. As Riven crumbles, Atrus and Catherine give thanks for the player's help, and the player leaves Riven through the star fissure that brought the original *Myst* Linking Book to Earth at the end of **The Book of Atrus**.

Myst: The Book of D'ni

Published in 1997, **The Book of D'ni** is the third **Myst** novel. The story was taken from Catherine's journals, and the events described within happened shortly after **Riven**, slightly less than 200 years ago.

After enduring the betrayals of his sons, the vindictive evil of his father, and the death of his grandmother, Atrus attempts to find purpose in his life by journeying to all of the Ages in the D'ni city Linking Books and trying to convince D'ni survivors to return to the city and rebuild their culture.

During the reconstruction, the D'ni survivors discover a long-buried temple containing a Linking Book to the Age of Terahnee, a land of impossible beauty and opulence. But things are not as they seem, and as Atrus, Catherine, and some of their followers soon discover, the Terahnee have grown corrupt and have badly mistreated the natives of the Age.

The Terahnee and the D'ni peoples are both from a now extinct world, called Garternay. While their roots may be the same, their philosophies are greatly different and Atrus feels a need to right the wrongs being done by his cousins, the Terahnee. The novel ends on a hopeful note with the birth of Atrus and Catherine's daughter, Yeesha.

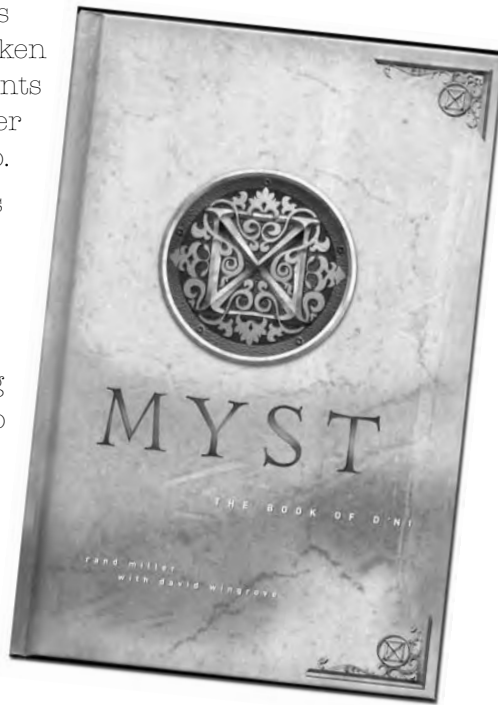

Myst III: Exile

Myst III: Exile was the first chapter of the **Myst** mythos not developed by Cyan (although Cyan provided a great deal of guidance during the game's creation). Developed by Presto Studios and published by Ubisoft in 2001, **Exile** is set after the events of **Riven** and **The Book of D'ni**.

Exile is the story of Saavedro, a man born and raised in an Age called Narayan. Atrus first made contact with Saavedro and the people of Narayan after the events of **The Book of Atrus** but before **Myst**. Atrus entrusted Saavedro with the care and teaching of Sirrus and Achenar, because Atrus had become somewhat obsessed with the restoration of D'ni at that point.

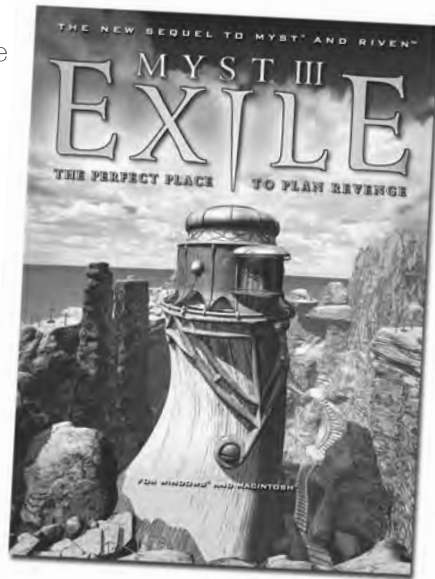

Unfortunately for Saavedro and Narayan, Sirrus and Achenar did not share their father's enlightened sense of responsibility for the Ages that D'ni Writers link to. On Narayan, the brothers began their pattern of plundering Ages that would lead to their imprisonment in Prison Ages, as seen in **Myst**. Before embarking on their brutal conquest of Narayan, they trapped Saavedro in the J'nanin Age, leaving him for dead.

After many years (and the imprisonment of Sirrus and Achenar), Saavedro escaped from J'nanin with the unintentional assistance of Atrus, who had written J'nanin's Descriptive Book years ago.

At the start of the game, Saavedro, now quite mad, uses a Linking Book that Atrus left behind to link to Atrus and Catherine's new home in the Tomahna Age (where they live with their baby girl of a few months, Yeesha). Though his original intent is to kill Atrus and his family, Saavedro eventually decides to hold Atrus's new Releeshahn Age hostage, under the misapprehension that Atrus can restore Narayan to its original, unspoiled state. It is the goal of the player to rescue the Releeshahn Descriptive Book and defeat Saavedro.

The **Myst** Mythos

Myst: The Book of Marrim

Book of Marrim is the next novel planned in the series, and the events fall between **Riven** and **Exile**. This novel will follow the tale of Marrim, whose life was sent spinning when Atrus and Catherine linked to her world and offered her a new path.

Myst IV: Revelation

Myst IV: Revelation was the second chapter of the **Myst** mythos not developed by Cyan (although again, Cyan provided a great deal of guidance during the game's creation). Developed by Team Revelation at Ubisoft in Montreal, and published by Ubisoft in 2004, **Revelation** is set approximately 10 years after the events of **Exile**.

In **Revelation**, Atrus has invited the player (the same "stranger" from **Myst**, **Riven**, and **Exile**) to return to visit him on Tomahna, where he seeks advice about the fate of his two sons, SIRRUS and ACHENAR, first seen in **Myst**. Although Atrus destroyed their Prison Age Linking Books nearly 20 years ago, he still has the original Descriptive Books for those Ages.

For two decades, Atrus has kept an eye on his boys and prayed that some day they might be rehabilitated. Both Catherine and Atrus have been visiting the boys via an elaborate Linking Chamber and special huts built on each of the Prison Ages, allowing the family members to interact through bars with no chance of SIRRUS or ACHENAR escaping...or so they think.

Atrus has also been teaching young Yeesha to Write in D'ni, and has introduced her to her brothers. With the good intentions of a 10-year-old, Yeesha unwittingly allows her brothers to escape their Prison Ages and link to Tomahna. When Yeesha is kidnapped, the player must discover if either SIRRUS or ACHENAR has been rehabilitated and try to rescue Yeesha before she is harmed.

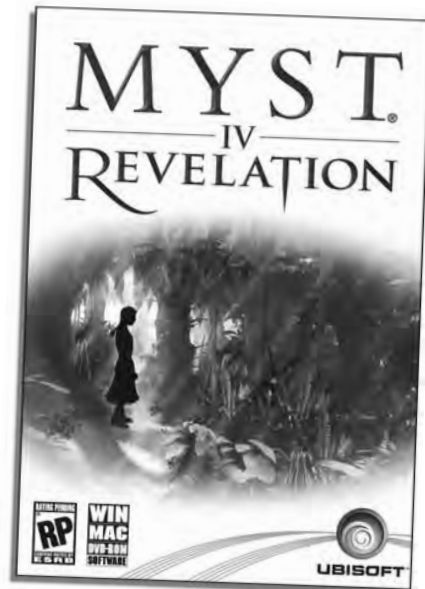

Uru: Ages Beyond Myst

Released at the end of 2003, **Uru: Ages Beyond Myst** was the first new Cyan-developed chapter in the **Myst** franchise since **Riven**. This long-awaited real-time adventure was the culmination of Rand Miller's desire to finally bring players to the lost city of D'ni. Initially, Cyan intended players to experience **Uru** in two distinctly different ways: as a standalone boxed product (referred to internally by Cyan as **Uru Prime**), and as a massively multi-player online experience, **Uru Live**, which was the multiplayer version of **Uru Prime**. However, with the demise of **Uru Live**, that content has been transformed into a series of **Uru** expansion packs.

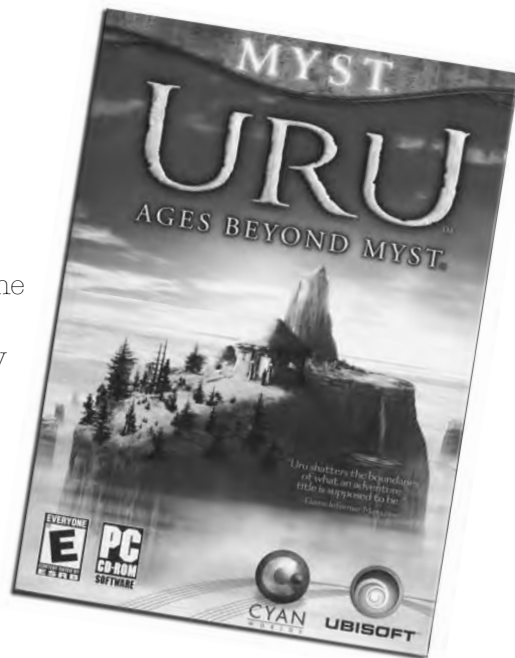

Uru

Uru, which at release was set in the present day (2003), places the player in the center of rising tensions between Atrus and Catherine's now adult daughter Yeesha and the D'ni Restoration Council.

At the start of **Uru**, the player meets Jeff Zandi, the son and heir of the late Elias Zandi, who purchased the area of land in the New Mexico desert around Anna and Atrus's Cleft. Zandi encourages the player to explore the Cleft and, in doing so, to undertake a journey designed by Yeesha that teaches the player about the self-destructive pride of D'ni and the D'ni's exploitation of a race called the Bahro (meaning "the Least" in D'ni).

Note

The D'ni word bah'ro was also used in The Book of D'ni to describe another exploited race of subservient creatures. Despite superficial similarities, however, the bah'ro of The Book of D'ni and the Bahro of Uru are two separate and distinct races.

The Myst Mythos

However, Yeesha's motives aren't purely altruistic. During the course of the journey, the player must find and acquire four Bahro Pillars; not until after completing the journey does the player realize that by doing so, he or she has released a Bahro from some sort of imprisonment. The end of **Uru** leaves the player with an unsettled feeling: What did I just do, and was it the right thing to do?

To D'ni and Path of the Shell

The journey that began in **Uru** continued in two single-player expansion packs, the first of which was **To D'ni**. Offered as a free download to make up for the promised **Uru Live**, **To D'ni** allowed the player to journey to the cavern city of D'ni and discover why a group of human archaeologists known as the D'ni Restoration Council decided to abandon their decade-long reconstruction of D'ni. **To D'ni** allowed players to walk down the D'ni streets that they could only glimpse from balconies and rooftops in **Uru**.

The second expansion pack, **The Path of the Shell**, picks up where **To D'ni** leaves off, taking the player on a journey to uncover Yeesha's destiny. Where **Uru** tells the story of D'ni's past and **To D'ni** tells the story of its present, **The Path of the Shell** shows the player the future of D'ni.

At the beginning of **The Path of the Shell**, the player learns of a prophecy that leads to two expansive Ages where a D'ni man named Kadish Tolesa attempted to convince the D'ni people that he was the One foretold to lead D'ni to a new period of growth and success. The player discovers that Kadish was a fraud and that Yeesha is, in fact, the fulfillment of the prophecy. Through the



Concept art of K'veer, where **The Path of the Shell** concludes (art by Victoria Brace).

player's own participation, the prophecy is finally completed. On the cavern island of K'veer, where **Myst** ended, the player and Yeesha together bring light to the cavern in a stunning finale.

Myst V: End of Ages

Myst V: End of Ages is the last chapter in the **Myst** story. Developed by Cyan Worlds and published by Ubisoft in 2005, **End of Ages** is set just a few years after the events of **Uru**, **To D'ni**, and **The Path of the Shell**.

In **End of Ages**, the same player from **Uru** has finally returned to K'veer; the room in D'ni occupied by Atrus in both **Myst** and **Riven**. The **Myst Linking Book** is here; however it is locked, and Atrus is long gone.

As the player explores, he or she meets up with Yeesha, who seems older somehow, and discouraged. The player realizes that what was set in motion with the release of the Bahro in **Uru** was only the start of what Yeesha requires of the player to help restore D'ni to its former grandeur.

A **Tablet of Power** is locked by **Slates**, which the player must gather through four breathtaking **Ages**. Along the way, the player meets **Esher**, one of the few remaining full-blooded D'ni, who narrates the histories of the **Ages** as well as his own views of Yeesha, the Bahro, and the player's destiny with the future of D'ni. The decisions that the player makes in **The End of Ages** determine whether or not the stories of Yeesha, D'ni, and the Bahro will have a happy end...or not.

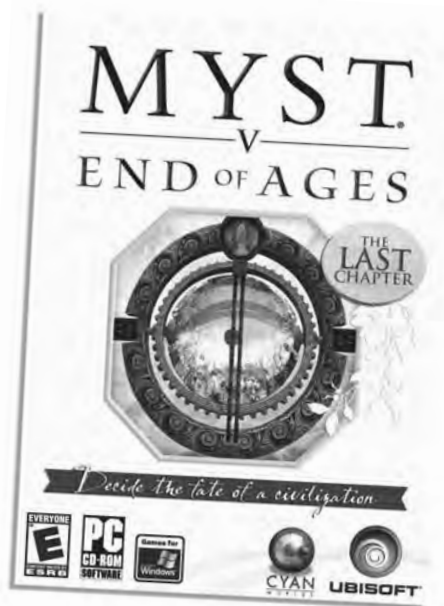

Behind the Scenes of Cyan and **Myst V**

Since the publication of **Myst** in 1993, Cyan (now Cyan Worlds) has recognized and acknowledged that they have great fans. Avid fans.

The fans of **Myst** games are well-known in the industry as thoughtful, intelligent, and fiercely loyal. They often are envied for the close-knit nature of their community, and examined by the industry as a "good example" of what a company would want in a fan base. Fans of **Myst** come in all shapes, sizes, and ages. Both males and females from around the world come together in the fan community to share one common love. Not simply a love of the games, of the books, or even of each other.

They love Cyan.

From the Fans

"The employees and personalities of Cyan have been uncommonly generous to us, the fans. Through fantastic searches sparked by a cryptic comment, the most devoted fans can get information long before it is released to the general public. Twice, at the annual fan convention known as **Mysterium**, we've been the first to see something completely new. In July of 2002, we went on a live tour of the D'ni city lead by Rand and RAWA [in avatar form]. In 2005, we were witness to the first private/public viewing of the **End of Ages** trailer.

Cyan never treats us as a strange group of crazed fans. We're people to them. They hang out in Cyan Chat with us, they know our names, and they patiently answer or cleverly evade our incessant questions. After all, the mystery is a huge part of this world. In late 2000, I had one 'Herby the elf' comfort me about my upcoming surgery. Although he didn't know me, and I have yet to discover his identity, he talked with me...and reassured me that I would be just fine. He may not remember me and that encounter, but I know I shall never forget it.

The most wonderful thing about Cyan is: To them, we are fans, people, and friends."

—Amberle "Saphira" Matthews, Virginia
Myst fan since age 11

Tim Larkin

Tim Larkin is an award-winning musician who has a gift for creating the perfect mood for any scene with his music. He has always been a favorite among the fans for his inspirational work and his great attitude. Tim has done in-depth interviews for **Myst**



fansites and has been a special guest in online chats with fans taking part. His willingness to share his passion with the community is something for which they will always be grateful.

Q: When did you come to Cyan, and what attracted you to it?

A: I came here physically to Cyan to work almost six years ago here in Spokane, but I'd worked on **Riven** before that from the Bay Area in '96-97.

What attracted me to Cyan actually at the time after **Riven** was probably when I came up here and saw the game they were working on at the time, which was called **DIRT** ["D'ni in Real-Time"]. I'd just finished up working on **Middle-Earth**, and it just seemed that the aesthetic was the direction that I wanted to go, the visuals were really compelling and they looked great, and so I thought that was the next thing that I felt was something that I wanted to work on.

Q: Now that **Myst V** is drawing the **Myst** series to a close, what are your reflections on the series and your part in it?

A: I think it was a great run. It's a great honor to be a part of a franchise like that, that not only had the following but had cutting-edge...well, pretty much everything. Every game that they did had cutting-edge graphics, had cutting-edge sound, had storylines that were great, things that set it apart from a lot of other franchises.

From the Fans

"Like a lot of [fans], I was a bit apprehensive of Tim taking over for Robyn Miller as musician at Cyan, but the music he wrote for the **realMYST** trailer and Rime allayed my fears. Tim's music is very true to the quiet ambience established by Robyn in **Myst** and **Riven**, even in places as familiar as the desert of New Mexico.

While the last two **Myst** games have included beautiful, full orchestral soundtracks, Tim manages to create a subtle mood and haunting melodies with solo sopranos and exotic Masai chants. I can't wait to hear what's in store for me in **End of Ages**."

—Gary "Alahmnat" Buddell, Kentucky
Myst fan since age 9

Q: What's your level of interaction with the fans, and what would you like to say to them?

A: I have a pretty minimal level of interaction with the fans themselves, I think. Occasionally there'll be a posting or something that I'll respond to on a [mailing list] or a forum, but it's rare. Music and sound doesn't come up as often as a lot of issues, I would think.

As far as what I'd say to [the fans], is thanks for their support over the years. It's been a great fan community, a real tight-knit community, which I think developers really appreciate. It's rare; there's probably only a handful of developers that really get that. I mean, you look at a lot of the triple-A titles, maybe companies that do things like **World of Warcraft** or have certain franchises that have been going for a while, companies like Blizzard and Valve, doing **Half-Life**, or the **Doom** community; there's definitely communities that follow them around, and they're very fortunate to have that. And I think we had that for pretty much the life of the franchise, and I think we're really lucky to have had that.

Ryan Miller

Ryan has always been good to **Myst** fans. When his novel, **Inkarri** was published in 2003, dozens of **Myst** fans were quick to pick it up and support his work by reading it and reviewing it for others. Many **Myst** followers enjoy reading Ryan's thoughts



on his blog, hunting for clues about the next game or story being worked on at Cyan Worlds. And knowing Ryan, there's a clue in there somewhere....

Q: When did you come to Cyan, and what attracted you to it?

A: Well, that's somewhat complicated. I was in high school when my brothers moved up here and started working on **Myst**, so I was obviously attracted because they were working on a game and it was a cool thing, and they were my brothers. And I got to be involved in little bits. And then I went to Seattle to go to UW [University of Washington] for a while and came back and ended up working at Cyan after doing some odd jobs after college. I think the attraction thing was kind of obvious; it just seemed like the natural thing to do (laughs). Am I supposed to work here? I think I have to!

Q: Now that **Myst V** is drawing the **Myst** series to a close, what are your reflections on the series and your part in it?

A: Well, it's been fun. It's been...honestly, I'm glad it's coming to a close. I've been working on it, like I just said, since high school, **Myst** has been in the conversation, so.... It feels...while it's been great to work on them, and an exciting adventure, I guess you could say, I really am happy that it's kind of wrapping up. For one, we get to wrap the series in a cool way, and it can be over for the fans, and there can be kind of a completion to the whole thing. And, two, that we get to go work on something hopefully fresh and new and not have to deal with D'ni rules and histories and language and all that stuff anymore. I think it's good for everybody.

From the Fans

"If you're looking for the person responsible for your bald patches and eye twitching while playing **Myst**, look no further than Ryan Miller. His creative genius, talent as a writer, and deep understanding of both the **Myst** universe and fan's minds allowed him to create puzzles that were unique and often difficult. Yet these puzzles would integrate the D'ni history and beauty of each Age perfectly, giving the fan a satisfied 'a-HA' moment at the completion of each one."

—Catherine "Jerle" Fagan, Pennsylvania
Myst fan since age 36

Q: What's your level of interaction with the fans, and what would you like to say to them?

A: My interaction is pretty limited. I'll go and surf

Behind the Scenes of Cyan and *Myst V*

forums every now and then and make very rare comments.

I think we've said it many times: they're just great fans. I am amazed at how much they put into being a fan and put into the games and keeping the interest level going at some level. I would thank them again for that, and for their support. They're always incredibly supportive of everything we do, even supportive in criticism and in what they like. So I thank them, and I hope they enjoy *Myst V*. I hope it's a worthy game to end the franchise that they've been following for so long. I hope we were able to satisfy them and give them a good conclusion to the whole thing.

Ryan Warzecha

Ryan was a strong supporter of Cyan and active community member for years before he moved to Spokane and began working at the company. Since his move "inside," Ryan has not lost touch with his friends in the fan base, which has served to amplify fans' affections for him. He replies to the questions and is able to offer great information to those who seek to learn more about Cyan and their work.



Q: When did you come to Cyan, and what attracted you to it?

A: Well, I started two years ago, approximately. And what attracted me to it was always seeing these brand new worlds and all the art, the art side in particular, and the logic puzzles. It seemed like this great company to work for.

I started getting really heavily into the fan base. I was a part of the Mysteria and stuff like that, little fan gatherings, and I had started talking to RAWA and a whole bunch of the artists at the time. I was living in Minnesota and decided to just move out here for the heck of it. I transferred with a bookstore at the time, but I had gotten a degree in multimedia design and was doing that on the side, fun stuff like that. But I was actually hired at Cyan for a Community Manager position for the *Uru Live* project. Well, as that ended unexpectedly, I was given the chance to take over other things and learn new things, so right now I'm actually a production assistant. I'm helping with animation and helping the artists in any way possible

on the *Myst V* project.

It's been exciting, it's definitely been exciting. I still talk to the fans, I answer questions and stuff like that too, but it's definitely exciting moving into the art side of Cyan Worlds.

Q: So you came from the fandom?

A: Yeah, definitely. It's a dream job, it really has been. It's one of those things that I always wanted to have, and I was very lucky to be able to pursue that.

Q: Do you remember how old you were and where you were when you saw your first *Myst* game? Which one was it?

A: It was *Myst*. It was in a classroom. The teacher was using *Myst* as a logic puzzle. Actually, my sister had kind of introduced me to it. It's funny, because she doesn't really play any of the games anymore, but she had heard about this game, and she said, "Ryan, you need to play this game!" So me and her were playing it, and then I really just got into everything, and then *Riven* came out, and after that, I just stayed in the fan base and read all the books and kept in touch. I've really enjoyed the experience I've had with the fans and all that fun stuff too.

Q: How old were you when you first saw it? Do you remember?

A: I don't remember, honestly. I just remember how it all happened. It's funny, because then while I was in high school, that same teacher who was showing us [*Myst*], we did some stuff on HyperCard, and we made our own little *Myst* type of game. He was one of those teachers that inspired you to go after your dreams. It's kind of why I'm here.

Q: Do you want to give him a shout-out?

A: Jim Norwood, yeah, definitely! But yeah, these Mysteria that the fans put on for the fans, it really does mean a lot to Cyan, and I don't know if they know that in particular, but we have such a great fan base. They've all been by us, they've always stuck with us, through good times and through bad. It's so good coming from that and seeing that side, and then coming to a place that knows that we appreciate that. They've had, what, five [*Mysterium Conventions*] now, something like that.

Q: Didn't they recently have one?

A: They just had one in Chicago, and I guess they had 70-something people there again, something like that. And I mean, yeah, it's a small little group, but it's a good group.

From the Fans

"Mysterium means to me the gathering of my family. There are no strangers in the Myst Community. I will always be indebted to Cyan for bringing to me a large family. That Cyan allows us to remain as one is the greatest honor in my long life."

—Lucille "Memiki" Cali, Minnesota
Myst fan since age 54

Q: Now that *Myst V* is drawing the *Myst* series to a close, what are your reflections on the series and your part in it?

A: I think the series as a whole is an excellent series, and I think *Myst V* is just a great way to leave. It's a good story, and I'm very proud to have worked on that project. It's a good story, it's a good way to leave, and I hope the fans enjoy it. I think they will.

From the Fans

"Ryan. Hmm...Exactly how does one make an imaginative quote about someone whose job it is to be imaginative? It's a duty bound for failure, and that's what makes it precisely **not** appropriate for Ryan. Keeping tabs on game development as a Producer, dealing with the high-stress pitfalls of Live Content Analyst, and yet it's apparent in his correspondence and his personal sites that he still has time to have fun. I'm glad to see that playing games and creating them don't have to be mutually dissimilar experiences, but it takes those like Ryan Warzecha to pull it off."

—Bryan "Blue Max" Siegfried, Ohio
Myst fan since age 24

Q: You sort of touched on this before, but I'll just ask again. What's your level of interaction with the fans?

A: I still talk to them on forums, and I still have some of the fans on my messengers, and they go to my website, and I talk back to them through that, stuff like that. I still talk to them pretty much daily, and I always read what the fans are thinking, what they're speculating. That's what's always fun, is just to see what they're thinking it's going to be. They see a screenshot and they say, "What's this place? Let's dissect it and figure it out!" That's what excites me.

Q: If you had anything to say to them as a whole, what would you say?

A: I don't even know, particularly. I hope they

enjoy *Myst V*, and I hope they like it as a game, and again, we appreciate them for sticking with us through thick and thin.

Eric Anderson

Eric "LemonLime" Anderson is known for his quick wit and even quicker rendering of stunningly realistic *Myst* scenes. Many fans got to meet him during a Mysterium Fan Convention in Spokane, and he regularly participates in the Cyan Chat room. Eric is also a photographer and his pictures have been admired by fans for years. Whatever project has Eric working on it, fans of *Myst* know that it will be exquisite.



Q: When did you come to Cyan, and what attracted you to it?

A: I've been at Cyan since the middle of 2000, and at the time, they were just starting work on what was to become *Uru*. At the time, it was being pitched more as...well, we didn't know what it was called, but it was a massively multiplayer, *Myst*-style game in real-time 3D. I'd been a long-time fan of *Myst* and *Riven*, especially having gone through art school and being a big fan of their art style, that's what really drew me to it. It's so visually rich.

At the time, I was getting into 3D graphics and had been working in post-production, doing commercial work and that sort of thing. I came out here and interviewed and found out that they were going to be doing a real-time 3D...essentially a sequel, even though it wasn't technically a *Myst* sequel; it was *Uru*. I got totally hooked. I was like, "Oh my God, I didn't think you guys could do this. If anyone's going to do a real-time game this rich, rightly so, it would be Cyan."

So that's what got me hooked, and here we are, five years later, just finishing up on *Myst V*, and it's been interesting.

Q: Do you remember your first experience seeing *Myst*?

A: Yeah, I had bought my very first PC with my own money. It was the very first PowerMac that they ever made, back in late '93, early '94. It had a CD-ROM drive, and I thought, "I guess I'd better try

Behind the Scenes of Cyan and *Myst V*

to find some cool software to run on this." I didn't plan on getting one. And this *Myst* game was really big, I heard about that. So I picked that up, and I just got sucked in. I played it every night for a month and got totally hooked. I was actually in school when *Riven* came out, and it was the same experience, only more so. I have nothing but good memories of both of those games.

Q: Now that *Myst V* is drawing the *Myst* series to a close, what are your reflections on the series and your part in it?

A: I think, as a whole, the series is very successful, and I think that the *Myst* franchise avoided a few possible pitfalls in that it was done by three companies all told—you have Presto doing *Myst III* and you have Ubi doing *Myst IV*—and they both did fantastic work. And I think us coming back to do the final game in the series and being able to contribute to closing it up correctly is really fulfilling. I don't think I would have felt as good about it if it had been another company ending the story. After having been here five years, it's hard not to take ownership over the world and over the characters. I hope we're doing it justice, but obviously the fans will be the ones to determine that.

Q: Speaking of the fans, what's your level of interaction with the fans, and what would you like to say to them?

A: I've been interacting with the fans since I got here, and there's a really, really, really supportive and strong fan community for *Myst*. And I didn't know that when I started here. I was like, "What? There's fans? What?" And as I got to know some of them, I realized that the fan base was really, really important to the franchise. They're the ones who, all through the games we've worked on, have really gotten the word out there and told their friends and given us support and feedback. It's been really good.

From the Fans

"One of the great things about Eric is how much he would hang out in Cyan Chat. He was just as much a fan as any of us. Plus, his artwork was simply brilliant and served as an inspiration to me during my schooling in animation (and today, too). I got to meet him during *Mysterium* one year, even, and a couple times in *Uru*. He's just been a great part of our community."

—Brian "SR388" Hagan, Pennsylvania
Myst fan since age 14

My level of interaction with them has been on chat rooms. There's several fans who MSN me regularly, and we chat directly. It's really good. As far as what to say to them: thanks for playing our games. I hope that *Myst V* specifically lives up to the standards that they're expecting. It's a hard bar to jump over!

Josh Staub

Josh is one of the reasons the *Myst* worlds are so photorealistic. He has brought the Ages of *Myst* to life for many fans who follow his work, both at Cyan Worlds and outside, with great interest. Josh has inspired many budding young artists in the *Myst* Fan Community to try their hand at 3D modeling, computer graphics, and Age creation. Josh's boundless vision and creativity have been and will continue to be an inspiration.



Q: When did you come to Cyan, and what attracted you to it?

A: Well, I first came to Cyan in the spring of 1994, so this is my 12th year here. I actually didn't expect to do this for a living, but I was attracted to the team and the quality of the work that was going on. I came here right after *Myst* was completed, so it definitely seemed like something new and exciting and of good quality, so it was something I wanted to be a part of.

Q: Had *Myst* taken off at that point?

A: Yeah, I think it had just started to take off. I'd actually kind of turned Cyan down a couple of times. I was in college at the time. But it was one of those things where it just seemed like such a good opportunity that I came over here to work for them.

Q: Now that *Myst V* is drawing the *Myst* series to a close, what are your reflections on the series and your part in it?

A: I think it's been great. I've always looked at us as a unique, creative company, and this franchise, the *Myst* franchise, has really excelled in its storytelling and in its visuals, which are the two things that I care the most about. So I'm really proud of what we've been able to do.

From the Fans

"Watching [Cyan Worlds] grow over time you can see the artists' work evolve and improve. Josh's work is a prime example of this. From the CG work on his site, to projects like **The Mantis Parable**, his work is a stunning example of what the dreamers at Cyan Worlds can create."

—Keith "Tweek" Lord, Portsmouth, England
Myst fan since age 16

Q: What's your level of interaction with the fans?

A: I don't have too much of a connection. I do lurk fairly often on the boards, so I'm familiar with a lot of the things that go on. I do get some communication with fans through some of my own sites. They contact me there, and I love emailing them. It's a great, great, really supportive fan community.

Q: What would you like to say to the fan community as a whole?

A: Just thanks for all their support and encouragement. We certainly have appreciated all of the hard work that they've done on our behalf, supporting **Myst** and keeping the fires burning when sometimes we're a little bit frustrated. They're always looking forward to what we've got to offer them, and that's a great feeling.

Bill Slease

Known as CyanBill, Bill is another well-loved and admired member of the team at Cyan Worlds. Bill shares his joy of intelligent games and adventure with all who talk to him, and his enthusiasm is contagious. Bill is thoughtful and kind and his words carry great weight among the members of the community. Bill's online blog shows his talent for the written word and flexing his gray matter.



Q: When did you come to Cyan, and what attracted you to it?

A: I came to Cyan in October of '99. I guess what attracted me was I'd played **Myst** (and then later **Riven**) and was just really excited about the idea of being able to tell stories in what at the time was a

new medium. I thought that was engaging and fresh.

Q: Do you remember how old you were and where you were when you first saw **Myst** or **Riven**?

A: **Myst**, I was working as a youth minister. It was in '94 or '95, so I was 24. And I actually used it in a Sunday school class.

Q: How did that work?

A: It worked pretty well. I just had people play portions of it and talk about the themes behind the game. It was maybe more strongly presented in the books and in the backstory, the theme of whether the D'ni actually created these Ages that they were Linking to or whether another entity, another being, made them and they had some responsibility for taking care of them. And that's where the crux of the tension was between Atrus and Gehn.

Q: Now that **Myst V** is drawing the **Myst** series to a close, what are your reflections on the series and your part in it?

A: Oh boy. Um. It's been a long journey. (laughs) I hope that the final game is enough of a closure for folks. I think it is. The gameplay is probably my favorite of all the games, and that's saying a lot, because I really enjoyed all of them. There's still so much backstory that hasn't been told that could be. I know that Rand's working on another book, so that'll be exciting to see. We don't even know what happens in there. It's exciting, and it's sad. We're all a little anxious to get onto something different, just for a change of pace.

Q: Do you think it's time to sort of wrap **Myst** up?

A: I think so. It's run a pretty good course. We've had a lot of different ideas along the way of things that just wouldn't fit with the **Myst** series, and we're all kind of chomping at the bit to try some of those things.

From the Fans

"If I had to compress to one word, the impressions that I receive from Bill concerning his work and role in the gaming community, it would have to be 'passion.' Along with a gnomish-type glee at being able to do what he does, he leaves you with the feeling that he really enjoyed the time that he got to spend with you.

During [a] visit to Cyan's headquarters, Bill showed a few fans some before-unseen game content. While I was immensely impressed with

Behind the Scenes of Cyan and *Myst V*

what I saw on the monitor, what left the lasting impression was the emotion coming from Bill. This wasn't just another accomplishment or milestone he was showing us, he was giving us a small part of his passion, his love, and his world."

—Roy "LRBolt" Smith, Texas
Myst fan since age 41

Q: What's your level of interaction with the fans?

A: I had a lot more kind of front-line interaction during *Uru*. I spent a lot of time as the interface between the people on the test servers, the beta testers, and the developers. But since then, I've tried to step back a little and take a breath. It's a tremendous source of information. The community's a tremendous source of information for us. It's a great resource, even as a developer, and I don't know if they realize that. If there's some facts we want to check, it's a great place to go. We oftentimes get information quicker from them than we do from amongst ourselves. (laughs)

And it's a great community full of really wonderful people. I play a lot of games. I'm involved as a player in other communities, and the *Myst* fan community by far is the most mature and well-intentioned and fun group of people to be with.

Richard "RAWA" Watson

Richard Watson is one of Cyan's most notable and most ambiguous characters. RAWA is adored worldwide by fans of Cyan's games, and is most recognized for his historian and linguistic roles. When asked how he got the nickname RAWA, Richard explained that it comes from his full name, Richard A. Watson. "In high school, I initialed everything 'RAW.' When I got to college, our usernames for the computer lab had to be four letters long. I tried to think of what would be good to add to RAW to make it four letters, and liked the sound of RAWA. It pretty much stuck as my nickname in college. I don't remember how it got started at Cyan, but it is probably from when we first got our email accounts." When RAWA isn't busy writing and



proofreading at Cyan, he's protecting his ice cream from evil penguins.

Q: When did you come to Cyan, and what attracted you to it?

A: I came to Cyan in 1992. I met Rand in August of 1992, I think. I had friends that knew him, and they knew that I wanted to work with computers, so they offered to introduce me to him. They didn't really know what he did, and they didn't know anything other than just offering to introduce me to him. And so I went over to his house, and he was working on putting a little animation on the water coming out of the spigot in [the] *Stoneship* [Age in *Myst*]. And I was impressed by it, because I had an old Apple IIe, and it didn't have anything like the graphics in *Myst*, so I pretty much knew that day that I wanted to work here.

Q: So you've been here for 12, 13 years now, right?

A: It's getting up there, yeah. I was hired at the end of September 1992.

Q: You worked on the original *Myst* then.

A: Yes.

From the Fans

"*Myst* is much more than just the puzzles; it's about exploring worlds, discovering civilizations, unearthing secrets.... The strength of the *Myst* series relies in that driving force that makes us want to learn and understand, uncovering the past to build new futures."

—Ian "Navah" Gazzotti, Italy
Myst fan since age 14

Q: Okay, so you've been here throughout the whole development process. So now that *Myst V* is drawing the *Myst* series to a close, what are your reflections on the series and your part in it?

A: It's been a lot of fun. It's been a lot of work and...I don't know. (laughs)

Q: How do you feel about the series ending?

A: Oh...I don't really like to close any doors. This is closing, but it could open up into anything else. So it's hard to really view it as an ending.

From the Fans

"RAWA is exceptionally dedicated to the *Myst* universe and its fan community. As a D'ni Historian, he's responded to numerous e-mails and forum posts in a depth that is not often seen elsewhere. It is this interaction with the fans and commitment to the story that makes *Myst* more than a game. It is what makes us more than players; it makes us explorers and friends."

—Andrew "Deg" Chernauskas, Pennsylvania
Myst fan since age 12

Q: You among everyone at Cyan probably have the highest level of interaction with the fans. How do you interact with them, and what do you have to say to them?

A: I'd just like to thank the fans, because they give us a lot of support. Basically, I interact with them via email. I answer most of the fan mail. There's a mailing list that I participate in occasionally. We have a Cyan Chat room that I haven't been in in a while, but I used to spend a lot of time in there.

Q: What do you think sets *Myst* fans apart from fans of other video games or entertainment?

A: There's such a wide variety of ways, I wouldn't say there's one thing that's different about them. But they like to pay attention to details, they like story with a lot of background to it, that kind of thing. We try and give them what they like. (laughs)

Q: Do you feel like they get out of the games what you put into them?

A: Pretty much, yeah. There's still some things that we have in there that they haven't figured out yet, but not many.

Q: Can you give one of them away?

A: Um...I'm trying to think of something. I know there are a lot of things where we plant seeds, and we just let them go, some things we don't just give away. We just keep gradually giving more pieces of the puzzle until the fans can put all the pieces together themselves.

One example of that is the relationship between the D'ni letters and the D'ni numbers. All the pieces were there, and it took many years, but eventually the fans put that puzzle together all on their own. We think that having questions is more interesting than getting all the answers. So we try to have a balance, answering some questions and

leaving some questions unanswered, so the fans have things to think about, discuss, debate, etc.

And having the patience to plant those seeds and waiting years and years to seeing those seeds producing fruit (as it were) is one of the things I'm proud that we have done with the *Myst* saga.

Q: Do you have any humorous or interesting anecdotes about the correspondence you've gotten from fans?

A: I've had a lot of bizarre emails over the years, from people who want to get jobs here and send in wacky emails and sending us packages.

Q: Weird packages? What have you been sent that sticks out in your mind?

A: The most clever guy just kept sending packages as if he was in the future and trying to get messages back into the past to us. (laughs)

Rand Miller

If there is one person who is synonymous with *Myst* and Cyan, that person would be Rand Miller. Since founding Cyan with his brother Robyn nearly 15 years ago, he has remained the constant driving force behind all of the company's ambitious attempts at reinventing interactive entertainment.



SPOILER WARNING: This interview reveals key plot points about *Myst V*, including the ending of the game. If you haven't played through it yet, you might want to hold off on reading this section until you've done so!

This interview was conducted on July 28, 2005.

Myst V

Q: Are you pretty much done with *Myst V*?

A: Yeah, I think we're wrapping it up. I mean, we're still doing some testing, and some stuff we're waiting on from Ubi, just some localization stuff and manual stuff that they're in charge of. But I think we're pretty darned close.

Behind the Scenes of Cyan and *Myst V*

Q: It's a very cool game.

A: Yeah, it's all right. This was the fastest game we've ever done. It was a little over a year and low-budget. Other than *Myst* itself, this was the lowest budget we've ever worked on. So it was a tribute to our team, being able to pull that off.

Q: Were any of the assets intended for use in *Uru Live*?

A: I think there was some design work that was for *Uru Live*. There was so much stuff for *Uru Live*, story-wise, where that was going, and all those things. So some of that we just adjusted, because *Uru Live* had a large story arc, and we were going to get to some of these places, but we needed to adjust certain things to pull back into just the pure *Myst* stream. So we did that. I don't think we had anything built, per se, or if we did, we rebuilt it, because the interface is a little bit different, with the point-and-click, first-person only, all of that. But that helped though, having all of the design work and some of the Ages already laid out or thought out helped with the expedited nature of the beast.

Q: And having an experienced team also must have been an asset.

A: Oh yeah. These guys are so good, and they know the engine. We adapted the engine, pulled out the multiplayer stuff and made it work in some other ways that were conducive to the *Myst* series. It worked well. We're still sad about *Uru*, but....

From the Fans

"After my early introduction to the idea of the virtual worlds in *Myst*, *Uru* was a natural extension into an interactive, gentle, and peaceful world. Sharing delight in beauty and pattern, storyline and adventure, was the 'coup de grace' in enriching my great fondness of these amazing worlds. Memories of sitting by the fountain in my 'neighbourhood' listening to a fellow traveler enchant us with his song, while the gentle murmur of water echoed in cavern will remain with me always, like recollections of trips to faraway places. Reading about the intrigue and lore of the D'ni and the Restoration effort sent tingles up my spine. More than an epic watched or novel read, this was for me! Where else could I share in this discovery of wonder but in the *Ages Beyond Myst—Uru*?! And I still do!"

—Joe "RR_Caz" Pedrosa, Ontario, Canada
Myst fan since age 40

Q: Yeah, I think all of us are.

A: Yeah, it was...kind of off-the-record, but the saddest thing about that is.... It's not bad to fail. I don't ever mind failing. It's when you're not sure.... Because you can always learn from failing. It's like, "I failed. Okay, good, let's learn from that." But we're not sure what we learned, because we didn't really do it. We needed three months to ramp it up and see what happens. And we (makes a cutting motion) didn't get there.

Q: It's tricky. I just did an interview with a *Myst* fansite, and they asked me what my take was on *Uru Live*. And I said that I wished everything would fail so well. It was really elegant. It was really ambitious.

A: Yeah. It was just...well, our resources were spent. And at some point, we needed outside funding for another three months, and I don't think Ubi wanted to go there, so it was just "chop it and go." Which is a shame. I mean, in the end, even if it had failed, everybody could have learned from it, the whole content rollout thing, let's see how people respond. And if the industry would have known if people want that or don't want that, that would have helped everyone.

Q: It was a totally different model. You had never seen a game promising to deliver more content. It was all about "here's a new sword you can wind up with if you take on these quests" or whatever.

A: Yeah, anyway, that's a side note.

Q: All right, well, what did you and the team set out to do with *Myst V*?

A: The story arc for this piece of the *Myst* story always ended in our minds where *Myst V* ends. When people play it, they'll realize that it wraps up one story nicely, and it opens things up as well. Any story does that. You wrap up your piece of the story and branch into other things. That's what *Myst V* does.

So those pieces have been in place for a long time, to go to this part. As far as doing it at this point in time, I think everybody was ready. *Myst* is certainly played out. Well-received, but losing some of its freshness. So we tried to do a few things unique in *Myst V* to reinvigorate it. One was the real-time 3D, which was unusual. Why would you end it by making such a dramatic change? Well, why not?

But, story-wise as well, it was a good time on

this fifth one to get us to that point. It'll be interesting, because I've said this to a few people: Grand finales are always about fireworks and fanfare and explosions and trumpets, but nothing in *Myst* is that way, so *Myst V*'s no different. We held to the quiet and yet very substantial effects to what you play or your decisions and choices. And I think it works well.

We brought in the older character for continuity, Yeeshah, and we've got a new character for freshness and to do some things we weren't able to do before.

It was good timing for all involved. It also allows us to move onto other things and keep us motivated and alert and awake. (laughs)

Q: To go off on a bit of a tangent, when you say that *Myst* had been sort of "played out," was that what you were trying to say at the end of the game, when you wind up back on *Myst* Island, and it's fallen into disrepair?

A: I think some of that was just to...yeah, good point, and there's a deeper statement there. Even *D'ni* itself, for people who knew *Uru*, we tried to make people realize that it's not what they thought, that there isn't some wonderful paradise where everything works perfect and there's no troubles and society's wonderful. And even in *Uru*, we started revealing pieces of that.

So with the final *Myst* installment, we wanted to let people know that *Myst* Island does like everything else does, it runs down. It runs down and runs out, and it's the people that keep things fresh and nice and make up what places are. And so, yeah, there was something there about it. Some of it is just shaking people and going "no, no, no, no." You expect one thing, but that's not how life works all the time. There's some interesting parallels with the whole arc of the story as well and our real-life story arc.

Q: You obviously had to cover a lot of ground with *Myst V*. What are some of the things that you knew you had to get into the game, things that you couldn't end the story without having in there?

A: That's cool. Well, without giving away too much, it was interesting, because we had a decision to make early on about how much ground to cover. Sometimes if you try to cover too much ground, it almost feels like you've got a sermon; you've just got to get the points across. And we didn't want to go

there. We decided early on, let's not try and wrap up everything. In fact, if anything, there may actually be additional questions after *Myst V* ends, but they'll be separate from where *Myst* went, and there'll still feel like there was still some closure, that there was a reason this wrapped around in the way it did. You can finally see where it all went.

And it was more important to us to...if I say too much, I'm going to give away ending stuff. To the previous point, one of the things we did want to show was *Myst* Island. We wanted to go back to *Myst* Island. We wanted to show that it's not necessarily what you'd expect, although that also gives away some stuff....

From the Fans

"I have always been interested in 3D graphics and fantasy-like realities. So when I first saw *Myst*, I was blown away. It inspired me to really push my limits at making 3D computer images and always trying to make it look the very best I can."

—Marcel Paans, The Netherlands
Myst fan since age 14

Q: This interview will be appearing after the walkthrough in the guide, so I don't think we need to worry about spoilers.

A: Okay. Well, one of the things we wanted to do was get people to Releeshahn. It's the "promised land." We've held out that carrot forever. That's where the new *D'ni* started, in the novels early on, that's where it was rebuilt, and people have wanted to go there.

You can't play the whole game there, though. That's a whole different thing, that's a new start, a new beginning, a whole new aspect of the story that we didn't want to go to. This one, though, can end by at least you seeing that it is a real place and saying you got to go there. And that was the most important thing.

Q: Would you say that Releeshahn was used in *Myst V* the way that *D'ni* itself was used in *Uru*?

A: Yeah. Together with the story in the books and the games, *D'ni* was always the place people wanted to go, and in *Uru* you got to go there. In this one, we wanted to do the same thing. We knew where the fans wanted to go and what was an intriguing place.

Behind the Scenes of Cyan and *Myst V*

And frankly, the whole “promised land” story is a wonderful one. That's what people want. They want a new, fresh start. They want a place that they've never been, to explore, to feel like they can start over. And what a great way to end, to have that there. So it worked well. It's been in there for a long time.

At the same time, it wasn't just *Myst Island* we got to revisit. We got to start in the very prison that you were in at the end of *Myst* and actually get out. That door wasn't blocked anymore. You could just walk through that door, which is something that I think is fairly satisfying for people.

And another thing that people have wanted to do is journey downward [to D'ni], to take some of the journey that's written about in the books, to walk down to some of those places. And in the book, it was a multi-day journey, so you can't make that a game, but you can at least see some of the highlights and some of the pieces. You get to experience it a bit. That was important as well as far as what things we wanted to bring forward and wrap up.

Q: So to extend the metaphor then, if D'ni was used as the carrot for *Uru*, is Releeshahn the carrot for whatever you're going to be doing next?

A: D'ni was the carrot to get people into *Uru*, but D'ni was dead. There was nothing there. So it was a great carrot, but it had no life other than what the people from *Uru* brought, and the interesting history [of D'ni]. Releeshahn's where the life is.

Now, with that said, I don't want people to think that we've tricked you, it's not really the end, we've got it in our plans to do all of this. Right now, we don't have any plans. We love having that door open. We love the idea of the promised land and all the stories we can tell there.

And even the novel, the fourth novel, is based on that. If we ever get it done, that's exactly what it's all about. In fact, in the extended edition [of *Myst V*] in Europe, we've included the first chapter—or preview chapter—of that novel, just to kind of tie things together. But right now, that's the only thing that's in our plans, story-wise, in the whole *Myst* franchise, just to write that fourth novel.

As far as the game goes, we've no plans to go to Releeshahn, no secret, subversive ideas to bring it back.

Q: There's no *Myst VI* secretly in the works?

A: (laughs) No, no. Now that doesn't mean that 10 years from now—everybody knows how this works. At some point, you go, “Hey, we should look at that again. It would be interesting to revisit that.”

Q: “Let's get the band back together.”

A: Yeah. But, right now, no plans.

Q: Going off in a different direction, where did the idea for the Bahro Tablet and Slates come from, both from a story and a gameplay perspective?

A: Boy, that's complicated. It's been around for a while. There's a rich history to the Bahro, which people never find out. It was part of what was going to come out in *Uru. Myst V* kind of hints at some of it, and you get bits and pieces. The Bahro weren't something we threw in at the last minute for interesting stuff. There was a parallel development of the Bahro and the D'ni that is very complicated.

So in *Myst V*, we wanted the Bahro to play a large role. That was part of wrapping this up. And if you played *Uru*, you know that we started hinting at that in there. We also wanted you to communicate with them, or have the potential to communicate with them. But if you know *Myst*, you know that we're certainly not going to throw up dialog boxes, and they don't seem to speak any kind of language that you could understand anyway. So early on, tying it into their larger story, it seemed that the most natural and best way to communicate with them is to write.

And that's where the Tablets came from. We decided to build some technology so that you can write symbols to them and they'll understand. It's rudimentary, and of course you can always do better, but we thought, wouldn't it be interesting to give people a taste of Writing? Write something on the Tablet. The Bahro either recognize it or don't recognize it, depending on how well you did, and the world changes because of stuff they do, or apparently what they do. And it works well. I'm real happy with the way that turned out.

Bahro Etchings

One often overlooked window into the Bahro culture is their method of pictorially representing important historical events. As their would-be liberator, Yeesha is a central figure in their culture, and the sharp-eyed fan will see her family's story told through a series of Bahro etchings in **Myst V**.



D'ni falls, in part due to the repercussions of the actions of Yeesha's great-grandmother, Anna (Ti'ana), as told in **The Book of D'ni**.



Catherine's home Age of Riven is destroyed by its own internal instability, but not before she and her people escape to Moiety (as seen in **Riven**).



An adult Yeesha leaves her father and mother in Tomahna and returns to the Cleft where Atrus was raised in order to begin a journey of self-discovery.



Yeesha and the D'ni Restoration Council (DRC) embark upon conflicting methods to revive D'ni (from **Uru**).

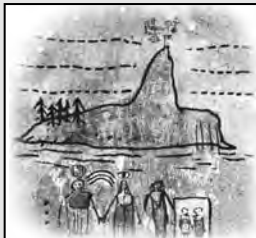

Atrus and Catherine arrive on Myst, following the events in **The Book of Atrus**.



Catherine gives birth to her third child, Yeesha, in Tomahna, just prior to the events of **Myst III: Exile**.



In D'ni, Yeesha meets a D'ni Writer who teaches her the Art of Writing Ages.



Yeesha meets other D'ni in her Quest for the Bahro Tablet.



Atrus and Catherine settle in Myst with SIRRUS and Achenar, prior to the events relayed in **Myst**.



SIRRUS and Achenar escape from their prisons, and Yeesha is kidnapped (from **Myst IV: Revelation**).



After the death of her teacher, Yeesha encounters the Bahro and commits herself to championing the cause of the Least.

Behind the Scenes of Cyan and Myst V

Q: What happened to Catherine? At the end of *Myst V*, Atrus says that he wishes that she could have been there to see Yeesha's success. Is she no longer with us?

A: "No longer with us," that's a good way to put it. At some point, maybe there will be a short story of that or whatever; but right now, it's just very vague and she's no longer around.

Q: Esher's a pretty intriguing character. What can you tell us about his origins, in terms of his story and your process of creating him?

A: We had always had plans in the story arc to finally meet some D'ni. There would have been some that would have been young enough [when D'ni fell] that because of their long life span [would still be alive]. It would be great to finally meet actual D'ni people. There were halflings and quarterlings and whatever—mixed blood—but wouldn't it be interesting to bring them back?

At first, actually, interestingly enough, in *Myst V*, we were going to bring back multiple D'ni Writers or historic figures. And it became apparent that that wasn't a good way to build characters. If there's too many, you lose the ability to build any depth into them. And so we thought it would be better to just bring one more complex character in. That's where that came from, somebody who would have a perspective that might throw a loop—once again—in the way you thought of D'ni, and the way you thought of Atrus, frankly, and Yeesha. It's like, "Wait a minute, maybe I'm looking at this from the wrong perspective. This guy is coming at this from a D'ni perspective. He's been here. I think I know what D'ni and what *Myst* is and what Atrus is and what they've done, but this guy is a part of the civilization that fell because of Atrus's grandmother. Boy, I never thought of it that way." And that's where we wanted to go. It follows the same kind of idea of bringing in a weathered idea, that this might not be what you thought.

Esher and the Bahro

The Bahro's version of their interaction with Esher is told in four pictographs found in Noloben. They detail his arrival in the Age after the fall of D'ni, the construction of his laboratory, and the experiments he conducted upon the Bahro, using the paralytic poison of the snakes native to the Age.

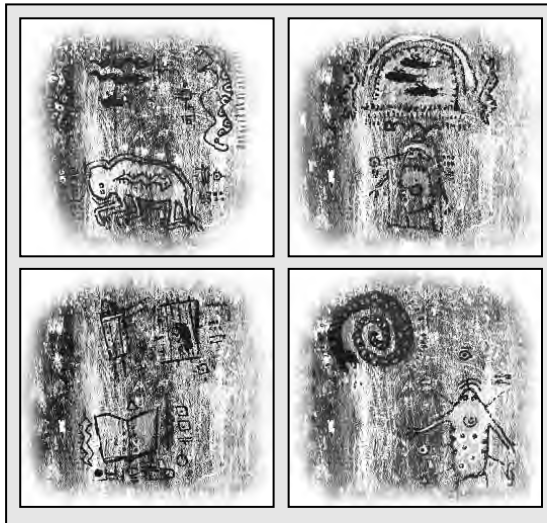

Q: Through Yeesha's journals that you find during your descent into D'ni, you get an idea of what happened to her between *Myst IV* and *Uru*, which led her to becoming a champion of the Bahro. Is that ever going to be presented more explicitly, or is that going to remain backstory?

A: I think it works better as backstory. Boy, there's so much information; that's a great question. There's so much there that all we did was hint at: befriending that Writer, learning from him, having the death. That was all stuff that I think was more likely to come out as part of the *Uru* experience. Just touching on the highlights or having her kind of give some highlights is probably as deep as we'll go. Who knows? The story's there.

I want people to realize that we've still only seen a small window into the *Myst* universe. The story's so broad. It doesn't mean you've got to tell every inch of the story. Getting those windows into it—getting satisfying windows into it—is what good storytelling is about. And so we have to make sure we pick the windows that are the most satisfying, and that might be a bit lean in any kind of a linear format. I don't know. It's something that we'll discuss.

Overall, I think our mindset is to move forward. It would be much more satisfying, speaking purely hypothetically future-wise, to get us to Releeshahn, get us to the new stuff, turn that corner and get us there, and reveal more of the history in flashbacks or in discussions or in revelations and move things forward.

The **Myst** Franchise

Q: If you think of the **Myst** games as being “Atrus” games and the **Uru** games as being “Yeesha” games, **Myst V** ties them together very elegantly at the end. Did you always intend for Yeesha and Atrus to meet and reconcile, or was that just a really good way to quickly tie off the story threads from the two series?

A: No, I think we didn't always plan that. We thought more that Atrus would fade out of the picture and Yeesha would take over. In fact, the continuing story has even more along that line. But back to the point, no, it just seemed like exactly what you said. As part of this wrap-up, it seemed so appropriate and so wonderful to have that burden of this shattered family lifted visually by having them have that connection. That was something that, when it came up, we all just knew it was right.

And actually, as a little side note, it's been a long time. Atrus is an old guy. And at one point in the speech, even at the beginning, the intro speech, he makes a small comment about going to great lengths to watch the end be written. It's just a comment you just gloss over if you're just listening to the intro. But he has done things to preserve himself to see how this all plays out. He wants to see what happens. And there are methods for him to make that happen. In other words, he wanted to not die before he saw what happened, and he made sure that happened.

Q: How do you think Atrus developed as a character, from his first appearance in **Myst** to his “final bow” in **Myst V**?

A: It's interesting, because I think he's similar in almost all of the games. He is a non-hero hero. He's a guy who actually does very little. He's very passive. Most of the time, it's other people who are doing the work, and yet somehow, he happens to be the person that this whole flow is channeled through. It's a very unusual character, in all the books I've read. And once again, in the intro speech, I think he says it all. He says, “once again, I am useless.” He's dependent on others for everything that gets done. But there's some wisdom in him that balances. There's a need for him to be a part of this. In other words, the whole thing would fly out of control if he wasn't there. And yet, he's incredibly inactive in all of it. Which is great. It's a little bit unusual.

And frankly, it's probably something we can all relate to a little bit more than leaping tall buildings in a single bound! (laughs)

From the Fans

“**Riven** was more immersive than **Myst**. Not just because of the graphics...the story was far more integral to the game than it was in **Myst**. Many people played through **Myst** without even truly understanding the story. I can't even imagine that being possible in **Riven**. Heck, we had to learn a new language and a new number-system while playing that game. Not many games can say that.”

—John Rizzo, New Jersey
Myst fan since age 27

Q: What about Yeesha? How would say she's evolved since she was first envisioned in the planning stages of **Uru**?

A: Yeesha was...boy, her character was developed way back. We knew—it must have been during **Riven** development, or even earlier—we knew she would be a pivotal character. I think she developed in ways that made her less mainstream. With all of her experience and everything she'd been through, we wanted her to be a homogenous mix of everything she'd experienced. And she'd experienced good and bad. She'd seen so much and done so much. And here she is, having to try and find herself.

So she's a mix of the best of her father and the best of her mother. There's even details to that story that'll come out later, as part of the **Book of Marrim**, I think. But finally, Atrus and Catherine say, “Wait, wait, wait, wait, wait. We've screwed up on our two sons. We've got to put part of ourselves in this daughter. This is our hope. This is the chance to make things right.” So she has the best of that.

But even that doesn't mean that someone is compliant. Her personality is, “I've got to find myself. I'm different. I'm unique. Why am I here? Why is so much dependent on me?” And that weighs on you. And so you see that she expresses that in creative ways. Once she left home to find herself, she began to take pieces of everything she experienced. And the details are hard to represent in the game, but even the tattoo on her face is something she found in a culture, and the pieces of cloth she found in her clothing are something she found in a culture. All of that weighs on her, down to the point where, in **Myst V**, that stuff either makes you or breaks you.

Behind the Scenes of Cyan and Myst V

And when you play **Myst V**, you're not sure what happened. You're not sure whether it made her, or which end she came out on. Which is a great character. I love those kinds of characters. They have a chance to be so human, because that happens to all of us. Everything we go through, we're either going to come out on top, or that stuff's going to push us down to the bottom.

Q: When you see her in **Myst V**, you're not sure if she's absolutely broken and defeated, or if she's still trying but she's just exhausted.

A: Yes, exactly, and that's what you want. That's easy to relate to.

It's also part of the balance. Some of that is hard in the game. We want to throw you loops. We want you to think, "Oh, wait a minute, I thought I knew Yeesha, but she could have easily gone off the deep end. Think of her family heritage."

Q: Right. There's a history of that.

A: Yeah, and then, "Wait a minute, she's saying things that I don't necessarily agree with. I mean, 'cursed Myst Island?' Oh my gosh, how could that be?" And then we throw in Esher, and you think, "Oh, there is a different point of view here. Yeah, I never thought of it that way. That's true."

We try to make you consider all of those angles that make you search a little inside to decide who to trust and not trust. And that's a great thing. That's the best thing about these games that we do. It's unusual for an interactive game to make you search inside for the choices you want to make in the game.

And **Myst** started out that way. We wanted you to decide which brother you were going to trust based on internal feelings about them. "Yeah, they're saying things, but which one do I really feel like I trust? Or neither?" And we really wanted to...boy, I wish we could get better at that. (laughs) That's the thing that excites me about where interactive could go.

Q: Are there any characters in the story that you'd like to revisit or wish you could have done more with?

A: Yeesha, I still think, is our most complex character, and so I like featuring her. I think there would be great ways to feature her more. I think we could have done more with her. Well, there's only a limited amount of interaction time you have, and I think certainly in both **Uru** and **Myst**

V, people have seen how much we like Yeesha, or how complex we think her character is and what we've done there.

I think if we'd had more time, we would have brought more of the D'ni back in, more of the Esher characters, and had possibly more than one. It would have messed up **Myst V** if we'd tried to do more than one, so I'm satisfied with how we did that, but there's some very complex characters in there that would be fun to talk to or visit if we had more.

And I think Catherine is an obvious choice, particularly her later years. She started to become a little hesitant to use the Books, a little concerned about where things were going and not wanting to Link because of what she'd been through. That stuff would be fun to at least have hints about that we've never really had the opportunity to do. I don't know that there's a lot you could say, but there's some things that would satisfy people.

Q: What would you say were some of your personal high points throughout the course of the **Myst** franchise?

A: **Myst** is definitely the top of the list. It was so surprising, so satisfying and surprising. Finishing it, or even finishing some of the Ages, and sitting behind people's backs and watching them play was by far some of the most satisfying times we've had. Not even the successful sales as much as watching people not wanting to stop playing and going, "Wait, wait, let me just try another 30 minutes to see if I can figure this out, or see if I go here." Or having them make the mental connections that we'd always hoped they would and not known if they would. That was just, oh, that was incredible.

So that was wonderful. And I have to say that, for me personally, the whole **Uru** experience, and in particular seeing a glimpse of what **Uru** might have been with **Complete Chronicles**, all that content [was a high point]. I think **Complete Chronicles** is available now for \$9.95 or whatever. That boggles my mind. The amount of content and space and work you can get for \$9.95 or whatever it is, is amazing to me. And I'm so proud of what we did there, what we were able to accomplish. I would have liked, of course, to have seen it through, and I still think that the whole content concept is the future, but those are the top points for me.

It's interesting, because my top points are **Myst**, our biggest success and **Uru**, which is our

biggest failure, but those are the two high points for me, as far as I'm concerned.

Q: So what would you say were some of the lowest points? Would **Uru Live** fall into that category?

A: Yeah. **Uru Live** falls into there because, and I mentioned this, the failure was not a failure that I can learn from. And I don't mind failing, I really don't mind failing. **Myst's** success covered over any failure I can have. (laughs) You get one of those in your life, and if you fail at everything else, it shouldn't matter. But what I regret is failures I can't learn from.

And we went out on a limb with **Uru Live**. We knew we did. We told everybody, there's no guarantees, we may fail. But it feels like we never got a chance to know if it really failed or why. It just kind of was cut off at the knees. So everything we worked for, the idea of continually having content that you could pump into an online experience, we still don't know if that works. I mean, after all that time and money and effort, no one in this industry can use that experience to say, "See, that works," or "See, that doesn't work." And that's a shame. That's got to be a really low, low point for us. Not the failure, but...you can't start that again. We can't do that again to prove now whether that will work or not. We were so close. **So, so close** to knowing.

Q: What do you think that the silver lining of **Uru Live** was, if anything?

A: My silver lining was the fact that **Complete Chronicles** is available for 10 bucks. (laughs) It's still there. At the very least, all of that content is still there. And that story was rich, rich, rich. I mean, the Words of the Watcher...there's an amazing amount of wisdom in there. We wrote all this stuff, the ongoing content, and at least now it's in a spot where I can say, "Look. Look at all that stuff." That's my silver lining. If that had all gone away, if there would have never been anything published that I could hold onto, that would have been terrible. But at least I've got that.

And I'm so proud of what we were able to accomplish. It was an amazing amount of content that we were able to build and have accessible online. Actually, there's a small amount of silver lining in the **Until Uru** stuff that we've done as well, being able to let the servers out there and let the community at least keep exploring some of those places. That's somewhat satisfying as well.

Q: What do you think were the repercussions of **Uru Live** not panning out, both in terms of Cyan and the industry as a whole?

A: I think there were some false assumptions actually, which is a shame. I think it set things back a bit. I think people assumed...they came to conclusions as to why it failed, which to my previous point I think were invalid. I don't think anybody will know whether it would have made it or not made it. We had 40,000 beta testers signed up. That's not trivial. That's a pretty good amount. The worst possible assumption is assuming that that type of entertainment, that online interactive entertainment that's not based on a treadmill but is based on ongoing content, won't work, and that **Uru** proves that, I think is the biggest mistake that people could make. That's what I regret the most. I think there were several assumptions made along that line. And I think that may set back the industry from having other people try it, which misses the whole point.

Q: The **Myst** franchise, particularly the first game, really pushed the boundaries of what a video game could be and caused people to rethink a lot of conceptions and misconceptions about what interactive entertainment could be. What do you think is **Myst's** legacy in the industry?

A: From the industry perspective, it's probably a little different from our perspective. The industry thinks **Myst** proved that adventure games could be mainstream, whatever "adventure games" are, and that it didn't necessarily take a shooter or a more traditional game to reach the mass market.

From our point of view, it was more about story. Our games have always been about taking the story and communicating it by wrapping it in an environment and a gameplay system, which I think is the opposite of how normal interactive games are done. Normally they take a gameplay system and try to attach an environment and a story to it. I would like to see what **Myst** does, the story method, I would like to see that played out. It doesn't mean it's superior, by the way. I think that people are entertained in any number of ways. You can be entertained watching a magic show or playing blackjack, I've said that before. But I would hate the fact that we're wrapping up **Myst** for us to lose that idea of, "Let's take a story and try and tell a story in an interactive environment."

And in fact, what I would love is to see people

Behind the Scenes of Cyan and *Myst V*

try that in new ways. One of the things we're looking at is a project called **LATUS**, and that's exactly what we did. Forget **Myst**, forget interactive environments, forget everything we've learned or known. Let's start with a story and try and communicate it with new interactive ways. Let's try and still have that story though that can touch people emotionally, that allows us to convey some deeper truths, but let's try it in a completely different way. I don't know if anybody will ever touch **LATUS**. It's risky and it's not like any kind of interactive entertainment that's ever been done before. You don't spend 10 million dollars to do that if you're a publisher.

But that's what I think of **Myst** as proving to us, is that that can be done; the story can be important, and in fact is important to people. The 10 million people who bought **Myst**, those people were intrigued by it because they were pulled into it, because it was the story that kept you going. If you just threw that environment out there and let people walk around, at some point they'd get bored of it. Early experiments in this medium were along that line, but there was no depth to it. It's that story that makes you want to dig a little deeper; to find out how it connects. I would love to see other people, including us, try and figure out other ways to do that.

The Fan Community

Q: Moving on to the fan community, Cyan and **Myst** have one of the most extremely dedicated fan communities out there. How does it feel to know that so many people out there take what you do so seriously and value it so highly?

A: Boy, it's humbling. It's unexpected and humbling. Although I understand it, because I've been on the other side. In high school, when **Star Wars** came out, I was one of those fans. And to be honest with you, I think I understand what that comes from. It has something to do with the deeper story, the untold parts of the story that allow you to discuss the things you don't know, to get together and try and fill in the holes and the blanks...the perception of history that is there that you don't know about.

When the first **Star Wars** came out, people were speaking languages I didn't know, and they were referring to historic events as if I should know about them. It made me think that they'd really occurred. And that stuff is intriguing. I got in on the middle of a story. Even the fact that they called

it "Episode IV" was intriguing. So I think that that's always been something that, to me, there's nothing wrong with getting in the middle of a story.

And I think **Myst** felt that way as well, that here was this guy saying something at the beginning about, "I realized the moment I fell into the fissure..." and it's like, "What? Fissure? Who are you? You're telling me things as if I should know them, and I don't even know what you're talking about." That's the kind of stuff that makes you dig deeper; that makes you form relationships with other people that who to dig deeper, so that you can talk about what you think and what they think.

So I understand where that comes from, but it's still humbling. It's humbling that something we can do can make people that intrigued. It's really cool. It's really, really cool.

From the Fans

"Even with the **Myst** series ending in sight, the energy and vitality of the community remains strong and vibrant. The reincarnation of **Uru Live**, in the form of **Until Uru**, has allowed people from all over the planet to continue to share, explore, and play, on an equal footing, in a place that is truly a joy to visit. With [player created] live events continuing to provide entertainment and interest in **Until Uru**, the Ending is far from being written!!"

—Larry "Rex Havoc" Brown, Missouri, **Myst** fan

Q: It's interesting, because **Myst** is not an easy story to follow. You have to pay very, very close attention to what's going on during the games. And even then, they raise as many questions as they answer. And a lot of the backstory was contained in novels that were out of print for quite some time. The whole premise of the game is almost an archaeological dig. Do you think that determines the kind of fans you attract?

A: Yeah, I think there are different kinds of people it appeals to, but there are a number of people who enjoy that digging. And I love that word "archaeological." I never thought of it that way.

To me, there's something in human nature that wonders what's around the next corner. I've said that numerous times. And I think the next corner can be finding out what happened or what will happen. So the more you dig in the games, the more you understand that. So people who lean more toward wanting to know more I think are drawn to be the deeper fans.

But there's also people who just relate to the fan community because they're nice people. The games themselves aren't about killing and destroying and destruction. In fact, they're about struggles of humanity, which we all have. We can relate to Atrus, and we can relate to Yeesha. And so there's that kind of human discussion that goes on too.

The thing I'm most proud of is that our fans are some of the nicest people. **Uru** was amazing, to see fans taking care of other people, answering questions, not trying to—well, there wasn't a method to do this—but not trying to grief them as soon as they got in, but actually trying to explain to them the ropes and see how things went. And so that's another humbling aspect, but one I'm really proud of, because that shows the nature of the game, and that's just incredible.

Q: It was pretty amazing. The times I went to **Uru Live**, I was stunned at the fact that there wasn't somebody waiting around just to insult someone. I don't think the game lends itself well to that kind of personality. If someone's going online to play a game like that, they're probably looking for a much different experience.

A: Yeah, it was interesting, because in **Uru Live**, there were a lot of things that—once again—we thought would play out in certain ways, but there was no way to test it until it went live, at least with the beta testing. And it was working. Those things were working. We'd always wondered about grieving and how much we'd have. And it was wonderful. It was playing out just the way we thought it would, so that was cool.

Q: Do you have a level of interaction with the fans that the fans don't know about? Do you “ghost” on forums and message boards? I know that there are still **Uru Live** servers running; do you ever pop in there?

A: I haven't lately, just because of how busy we've been here with **V**, although I've a close relationship here with people at the company that do that stuff on a regular basis, so I get regular updates from them. “What's going on now? What's the buzz? What are people talking about? What are they having problems with? What are they postulating? What are they thinking?” I usually get that from those guys, from Ryan Warzecha or RAWA [Rich Watson], those guys who are really in touch with the fans, who in fact, in Ryan's case, came from the being one of the fans to work here. And I do actually ghost on occasion, just to follow some

threads through, but it's a lot easier and more efficient for me to get the highlights from someone else, in most cases.

Q: How difficult would you say that it is to balance the commercial sensibilities of appealing to a wider audience of more casual players with making sure that you keep the devoted, hardcore fans satisfied?

A: It's real hard. It's been hard in every one of the games, and I don't know that we've gotten it right. **Myst** was a great balance. **Riven** was not necessarily a good balance, although an exquisite game, just a remarkable game. But even in that, I'm not sure that we got the balance right. **Riven** was a highlight, but the gameplay and satisfaction level may not have been exactly right for everyone.

So we pull back and we learn and we try to go in both directions. The hardest part of all of this is that there are different people who play the game, different styles and personalities, and we're trying to get a balance that pleases as many people as possible. The easiest way to accomplish it—well, not the easiest, but the conclusion that we've come to, now that we're ending this (laughs)—is, we think that the majority of people actually enjoy exploring more than anything else. They're not the puzzle-solvers, and they're not the dig-deepers. They're the people who like to just explore interesting places, and they want the story to come out fairly easily.

I think that **Myst** appealed to them on the first island very well. They could wander around, and bits and pieces of the story would draw them in, and they hit the wall when it came to getting off of the island, and they have to solve that puzzle.

So overall, I think that's the largest group of people that play the game. But you've got to try [to appeal to] the puzzle-solvers and “archaeologists” in addition to that. The “archaeologists” are easy, because all you have to do is what we do, and that's build detail into the environment, and they're satisfied. But build real detail, not just fluffy little decorative stuff, but make a sentence in D'ni that means something, that's there for a reason, that's there because somebody wrote that there. And make this hut this way because these people have a history, and they built it this way because of the tools they had. And all those things that the “archaeologists” will find and be satisfied with, that's easy as well.

The hard part is the puzzle [solvers], the “achievers,” because if you make it easier to get

Behind the Scenes of Cyan and *Myst V*

places, you have to make the puzzles easier. If you make the puzzles easier, they don't feel challenged, they don't feel satisfied. So I think you run the risk of losing some of those people.

I think the *Myst* series has gradually moved to a "puzzle" game. I think over time, the puzzles have gotten more difficult, more "mindbending" puzzles. And I think that's unfortunate. I think we've actually lost some of the mass-market people who were first drawn to *Myst* because of that. I think if I could go back and time and steer it, I would steer it the other way. So yes, to the question, that balance is incredibly difficult, for the most part.

Q: Obviously, a lot of the *Myst* fans are going to be heartbroken if this is truly the end of the road for the franchise. What words of reassurance do you have for them?

A: It doesn't take more games in *Myst* to keep it going. There's plenty of instances of rich, thick storylines stopping, and yet, the fans and the interest and the amazement continuing. If you look at *The Lord of the Rings*, how that was received when it first came out and how long it went with people just intrigued by the depth of it, making up their own stories, wondering about that world and those places. And I think it's the same thing. Tolkien built so much history depth into that that it just lent itself to discussions for years to come.

Q: It gave birth to *Dungeons & Dragons*, which is basically a way of telling more of those types of stories.

A: Yeah, yeah. So, in the end, even if there's not ever another *Myst* game, there's enough questions and rich...I mean, probably not to the Tolkien level, but there's enough to keep things going for a long time, as far as I'm concerned. Just because you stop adding content, the content you've already got and the story that's in the background is still there. It's always there.

Q: I've also got a few questions here from various *Myst* fans. Here's the first one: How do you get such talented people to come and work at Cyan? And, I'd like to add, how do you get them to relocate to Spokane? (laughs)

A: (laughs) Well, there's two things there. I think we're unique enough that it's an interesting diversion from doing normal games. And if you're not going to go to Hollywood and work on CG stuff, or you're not going to work on the next engine for a 3D shooter, there's not a lot of choices, and we're

one of the interesting little skews that makes you go, "Man, I'd like to do something in this industry, but I don't want to do the same old thing."

So that makes it easy. Spokane makes it hard. (laughs) Although Spokane certainly has an appeal to people who live here. Once you get established here, you realize the benefits. And there's plenty of things that irritate people about Spokane, but it's nice to be able to actually own a home!

Q: Yeah, that's not something you're able to do in San Francisco!

A: Right, exactly! And there's so much to do here, outdoor-wise. Within four hours is Glacier [National Park]; you can go to Yellowstone [National Park]. Over the weekend, I went to some place in Montana I'd never heard of and walked in these 200-year old cedar trees with this little stream going by, and it was within a couple of hours of here. I didn't even know it was there. That's the kind of stuff that makes it worthwhile. The saying we've said many times about Spokane is, "It's a nice place to live, but I wouldn't want to visit there." (laughs) I'm not sure that we've got quite the excitement to warrant a visit, but it's a great place to live.

Q: Well, a lot of places that you have to live if you want to work in video games tend to be big cities, and if you don't have that big city mentality, that's another thing.

A: Right. We don't have that buzz and that energy that a big city has, and so if you come here for a week and you want that, oh my gosh, you're going stir crazy. But again, last week, I went canoeing on a river that's a mile from my house and saw three moose as I'm going down the river. I mean, where do you do that? That's just crazy.

From the Fans

"Cyan couldn't have picked a better team to continue their legacy for the third installment. With *Exile*, Presto Studios were able to draw on the rich history Cyan had created, and at the same time, bring a unique feel to the worlds. One of the Millers' original goals for *Myst* was to create a fully immersive experience, and with *Myst III*, I found the worlds more immersive than ever—I was able to put my headphones on and really experience that goal realized."

—Matt "Eat My Shortz" Giuca
Melbourne, Australia, *Myst* fan

Q: Here's a fan question about the **Myst** games that were not developed by Cyan [**Myst III: Exile** and **Myst IV: Revelation**]: How true to the Cyan vision do you think they are?

A: I think they've been true to the **Myst** path. I mean, some of it is because we've worked with [the developers], but not held the rein closely. Heaven knows, if we hold the rein too closely, it just chokes. And that's the last thing we want to do to creative people, and Presto [developers of **Myst III**] was full of creative people who had a story to tell that was great, and it was part of the **Myst** story, it fit well with the history and explained a few things, and it still gave them freedom to expand it themselves.

Same thing with the studio in Ubi that worked on **Revelation**. Those guys were fanatic, made up of great fans in many cases, doing a wonderful job. And once again, the story comes out and you see some of their creativity in addition to the storyline. It's not all perfect. Some of it may not be as good, but some of it is better, frankly, than what we could have thought of, story-wise and production-wise. So I'm very satisfied. For third-party work, what people were able to accomplish, it's pleasing.

From the Fans

"Not only did [**Revelation**] stay true to the original vision the Miller brothers had for the series but it also expanded beyond that, revealing worlds and stories beyond anything done so far. With **Revelation** you didn't just feel like you were playing a game—you were exploring this unknown world as if you were really there."

—Daniel "Dan'ni" Sadowski, Poland, **Myst** fan

Q: How do you feel about the fact that folks have basically chosen their career paths because they want to work on the **Myst** vision?

A: Well, once again, that's humbling but easy to understand. I mean, I'm partially in this industry because of things that shaped me early on, from reading **The Lord of the Rings** and from seeing **Star Wars** and from seeing early CG 3D stuff. I mean, I got books when I was in college before there was 3D as we know it today, when it was just blocky shapes moving around, and thinking, "Oh my gosh, what is this?" So that's understandable. Humbling that we can be part of that, but yet very cool, because I was shaped the same way.

Q: To abruptly shift gears, I've got a couple

questions about the upcoming **Myst** novel, **The Book of Marrim**. What's it about, and what's the state of it?

A: Well, it's kind of what we've said for a while. We have the outline, and the outline continues to develop, and it's great. I love the entire story; the story's so deep and rich. We just don't want to screw it up. And so we've written a chapter or two, just trying to get our legs and see what we could do if we were going to do it ourselves. We went through a whole writing of it from [David] Wingrove [co-author of the three previous **Myst** novels] that defined some things, but we weren't quite satisfied with it, and we don't want this to go out unless it's right. We're not in a hurry. When it comes out, we want it to be an epic. We want it to stand on its own. We want people—especially **Myst** fans, but everybody—to read it and love it, so we want to make sure we do it right.

It's the story of Releeshahn. What is that place that Atrus wrote? If you could write an Age to start over, what would you write and why would you write it? And that's what **The Book of Marrim** is.

Q: Another fan question. I think we know the answer to this one, but maybe you can expand on it: Do you support the idea of **Myst** fans continuing the story via writing and amateur game development?

A: Oh, absolutely. That's cool stuff. When you fill in the holes that way, that's great. You always run the risk of the better stuff becoming more official, or conflicting with how the story actually does go, because we kind of know parts of that that the fans don't know. But yeah, any creative effort along that line is great. I mean, if they know the risk involved—"Oh, I conflicted with the story, uh-oh, my stuff's not right anymore"—as long as they understand that risk, it's just a blast having them do that.

We've had discussions internally, serious discussions, about how can we let the fans Write Ages in **Until Uru**? What tools can we release, the legal ramifications, how do we do that? We have ongoing discussions about putting the Art of Writing into novices' hands, letting them Write their own Ages. The risk is, you get Ages that are pretty dangerous, but yet you might get some gems, as people get an idea of how Writing Ages works.

Q: And I think there are parallels to be drawn between Writing an Age in terms of the **Myst**

Behind the Scenes of Cyan and *Myst V*

universe and creating a 3D model of a world in programming terms.

A: It is amazing to me the parallels between what we do and the D'ni culture. We're the masters, we've learned the Art of Writing, but for those who don't know all the rules, you might write some stuff where you fall through the world and things don't behave correctly, but you can Write worlds, and that would be just really cool.

As far as **Uru** went, if it was successful, we always wanted to go there. Without success, maybe we can at least make that happen.

Q: Another fan asks: What did you do to get through the tough times when you were making *Myst*, before you knew that it was going to be successful?

A: Boy, they didn't seem tough! (laughs) We were working on a shoestring budget, but we were working with a Japanese company that was giving us our milestones. We were naïve and young and working out of home. We didn't know you could go back to the trough and get more money. That just wasn't the way we did business.

We're not the best business company in the world. And frankly, I'm a little bit proud of that. We make decent business decisions, but we're more concerned with just making our stuff cool, for the most part. We don't want to get screwed, but that's not the most important thing.

Q: And you don't have Atrus bobbleheads everywhere.

A: (laughs) Yeah, right! So, in our naïveté, we came up short and needed money, and it just so happened that there was a settlement with a company that had stopped paying us, and we sold old children's projects to somebody else and got some cash in and put it back into the product. We just sort of okie-doked our way along. And that's great if you can do it.

Q: So was it just a case where everything you were doing was just so new and so exciting that it didn't feel like work?

A: Yeah, it felt like work, but in that garage band kind of way. We worked long hours: Get up in the morning and go to work, work all day, go eat lunch, go back to work, go eat dinner, go back to work, work late into the night. But you're at home, and my kids were around, and it was fun, listening to music and seeing cool stuff come from Robyn and

making it work, and feeling like we could walk around in this world. We just thought it was cool. And there's something good about a garage band working on a song that they feel really good about. It keeps you going.

Q: There's a really strong family element to Cyan. You just talked about having your kids around and working with your brother Robyn, and now you're still working with your brother Ryan. And there's been a really strong family connection in the games. Can you comment on that a little bit?

A: Oddly enough, and I'm not sure how, I think companies are shaped by the people at the top of the company. And I've seen that in some fairly large companies. I remember starting to work with Broderbund, our publisher for *Myst*. I'd met Doug Carlestone, and he was such a gracious, wonderful guy. And Broderbund was a big publisher. I don't know how many people they had working for them, I'm sure it was in the hundreds, and it didn't seem to matter. It seemed like what he was trickled down. The stuff he said, the expectations, whether he was active or passive, they dribbled down throughout the company. And I liked that. That was a positive.

And I hope the same thing happens here. We're a living. Bottom line is, we're a living for a lot of people. And regardless of what you think of the product and what we're doing, people are supporting families as they're doing this. And that's probably one of the reasons we're not the best business company as well. We do whatever we can to maintain that, to keep people here and try not to mess with that. It feels like there's family stuff going on. It sounds a little corny, to say that you're a family, but there are things that come from us actually starting this as a family with a couple of brothers that I hope dribble down, where we feel obligations that are much beyond business. Business is not business here, and I hate that saying. It's not. There are much better and deeper things here than business.

Q: It's funny that you mention that, because I read an interview in the *New York Times* recently about Costco and the way they treat their employees, which is just phenomenally well. And they retain a very experienced, motivated staff. It almost seems counterintuitive, in the business world, but going back to the beginning of the conversation, when you were talking about turning out *Myst V* so quickly because you have this dedicated, experienced team, it actually makes a lot

of sense. It seems that investments in people generally pay off.

A: Yeah. That's been a highlight of all of this, is meeting incredibly talented people who do amazing things that just blow me away. We got started doing simple little things while making **Myst**, the stuff these guys do is amazing, to see the talent. I've told them that. I continue to work with some of the most talented people I've ever met.

Q: It's obvious. I visit a lot of developers, and there's a unique vibe here.

A: We have our ups and downs. People get unmotivated, and there's interpersonal issues and all those things, but you can't help but have that in families. But it's been a great place to work.

Q: Another one from the fans: Which character in **Myst** do you admire most? Who do you mimic, and who mimics you?

A: (laughs) You know, I think I admire Atrus, and I probably relate to him as much as anyone. I don't know that there's parallels with my life, but he's had extraordinary experiences that he's just kind of blundered through. He's always gotten help; it's never just him. But he's managed to maintain his composure, he's managed to be a rock. He's been some level of stability for those around him. Even if he's not the hero, even if he's not doing the work, he's at least a foundation or a source of stability.

And I like that. You don't always have to be the guy with the limelight shining on you to accomplish great things. You can just be someplace for people to anchor, and good things can happen.

Q: Another fan asks: How can we make the industry more kind as a whole?

A: (laughs) I think that there will be some very natural things happening to make it more kind. I still look at the entertainment industry—and it's getting harder and harder to do this—as being somewhat of a niche industry. I think the more and more you get mainstream into the industry, and you get people outside of the [hardcore] gamers to play games, it becomes much more broad. The entertainment styles have to become more broad in order for that to happen. You're always going to have what I still consider to be niche [games], even though they're the best sellers, like **Grand Theft Auto**. Yeah, it's a best seller, but that just proves to me that the industry is still just satisfying a niche.

Because the public at large isn't buying games.

You're still not selling to the general public when you're selling **Grand Theft Auto**. And I think **Myst** and **The Sims**—what I would consider to be two pretty kind games that sold 10, 15 million copies—then you're starting to see, “Oh, the mass market's huge, and they want kind games. Well, maybe if I want to sell not just a couple of million, I should make something kinder.”

But that can just happen or not happen. It's interesting to me that you still have the freedom to do any of the other games, as long as the right groups are protected. We still make R-rated movies, even though R-rateds aren't the best selling, because people have the ability to express themselves, and we protect people who shouldn't be seeing those from seeing that. But because the general public does like PG and G movies—in fact, they're the biggies—and PG-13, we have incredibly wonderful movies in that kinder aspect, or even [rated] R, that touch a different storytelling aspect. The same thing will happen in videogames.

Q: The pressure of market forces.

A: Yeah, I mean we're still just so young, so young.

Q: I draw a lot of parallels between the game industry and the comics industry. Comics are basically being sold almost exclusively to a niche market of superhero fans, and then you get a book like **Maus** that comes out and wins the Pulitzer Prize and outsells the top superhero books 10 times over. And you can relate that to a **Myst** success story. What you think is the mainstream in your industry is in fact just a niche.

A: Right, that's perfect.

Q: And you're starting to see now, with the uproar over **Grand Theft Auto**, movements to ban game sales to kids and things like that. And these are battles that the music industry and the comics industry had to fight in the '80s and '90s.

A: Sure, it's just growing pains. “Wait a minute, we want to express ourselves, but we've got to figure out how to protect people from that expression.” And that's just the growing pains; it'll work itself out.

Q: I was just having this discussion with someone who asked me about games like **Grand Theft Auto**, and I said that I didn't think a 10-year old should be playing them, but a 20-year old should be able to buy whatever he wants.

Behind the Scenes of Cyan and Myst V

A: Yeah, we're free enough that we can do that, but you've got to have some of that stuff in place. And frankly, I don't think we do a good job of protecting, but that's just growing pains. Same thing with the Internet. Good grief, it's not that you want to limit or censor, but you have to protect. One of the strongholds of society is that you have to give parents the ability to protect, and you have to help them with that. You can't just rely on them, because kids get more and more freedom. You have to actually help them until they reach an age of reason and they can do what they want.

Q: There are things that an eight-year-old's brain is just not wired to process.

A: Yeah, we know that. To think otherwise, you're just in denial. Good grief, the people who rant about censorship and stuff, it's just like...whatever. We'll just let your kids run wild and do what they want. I don't think you'll want them to.

Q: Well, I don't want your kids running wild! (laughs)

A: (laughs) Yeah, exactly! I want my freedom, but I don't want your kids going nuts while I have my freedom too!

It's interesting to me, the **GTA** stuff. There's going to be some unfortunate whiplash and some ups and downs as we sort through the growing pains of this. But they pushed it with the mod content...

Q: They really pushed it.

A: They pushed it way far. But in a way, it's like, "Well, I guess we'll figure out how to deal with that now." The interesting thing is that you get the whiplash with **The Sims 2**, with people going, "Wait a minute, you can mod **The Sims 2** really easily and see nudity in there." So now we'd better figure out how to deal with this.

Q: All right, back on topic, here's another fan question: Do you think video games are inferior to books?

A: No, not at all. I don't think they're superior either. In fact, one of the reasons I've kept going in this industry is trying to see how far games can go as far as becoming more of an art form. And I've got my own definition of what an art form is.

One of the things we've talked about, and I've said this before, is that storytelling is about living someone else's adventure. A good storyteller brings you into their adventure or their

experiences, their emotions. Interactive games have the potential of making you the storyteller. You can experience those things. So in a lot of ways, they have the potential of letting you experience it, rather than read about someone else's experience, and that's a great thing. It's a great alternative.

My opinion of art is still that it's a crafted work that someone makes that tells you a little something about yourself or the world. There's a lot of things that the world at large puts in the category of "art" that I don't because of my definition, but I'd love to see interactive go that way. And in my definition, there's plenty of books that aren't art, but pushing interactive to where it actually teaches you about yourself is a great thing.

Q: What do you think would be the advantages and disadvantages to each medium?

A: A book, or any linear medium, is great at manipulating. When you can control the flow, you can manipulate a person so effectively, their emotions in particular. And emotions are a great way to teach. So you can make your point, people understand it, they can relate to it because they've been there—if you do your job well. And you can lift them up and drop them down, and the flow follows exactly the way you want to manipulate them, which is powerful.

Interactive doesn't have that flow. The only power you have in interactive is you feel like you're doing this. "This is me, this is me in this place, and I'm doing this." And that has its own powerful repercussions.

We diminished that, because we've let people do such vile things, I think, that in a lot of ways, I lose some of the tools at my disposal. Like in our games, if you actually did let somebody kill somebody to make a point, to make them feel something, I'm not sure that they would if they've played other games. "Big deal. I shot him. So what?" But we can do that in other ways. You impact your environment and things seem real. "Wait, I made this choice, I did this, this felt like something I decided." And that's powerful as well.

Q: If there were just one or two things that you'd hope that **Myst** fans would take away from the series as a whole, what would they be?

A: I think that, in the end, it's about what's important. And this has to do with us trying to make something that was a little bit deeper. And I

think we failed miserably at most of it, but at least we were trying. But it's about what's important, and every one of these **Myst** games challenges that a bit.

The whole idea of Writing Books and Writing Ages and that power...realizing that that's not what's important. Power corrupts. Power is just sitting there, ready to be abused. And it takes a deep, underlying commitment to overcome that. Atrus managed to do that throughout. That temptation was always there to be incredibly powerful, and it was not what he was looking for, because underneath he wasn't that person. Underneath, he had already conquered that.

And that's a message I love, that it's more about people and the way you treat them, and kindness, and seeing even people who are weak as something more, rather than wielding your power as being the more important thing.

The Future

Q: Last question: Now that **Myst** is being laid to rest, at least for the time being, what's next for you and for Cyan?

A: It's interesting for us, because we're at a point in time where we've got a few designs that we've worked on that are not **Myst**-related at all, that are some interesting experiments on our part. We're having to follow the normal procedures here, the way publishing's done. So we've taken them to a few publishers, and we're seeing if we get any response from them to fund the things. So at this point, we're kind of at this scary position, where we don't have a lot of reserves in the bank, and we're trying to get something that a publisher will say, "Yeah, we'll fund you for that. We'll write you the first check and see what happens."

So we've come up with proposals that are somewhat flexible. The **LATUS** one, we thought at first we would get someone to bite on, but we realized later on that it's too out there. Publishers want something new, but not that new. I'm not sure that we'll get a chance to do that unless we get another hit and maybe try bits and pieces of it on our own. And there are some publishers who expressed some interest, but I think that's a long-term thing.

And we actually, just to shore things up, have come up with some designs that are completely different but give us a better chance at keeping everybody employed, something a publisher might want, something that fits more in what they're

looking for game-wise that's not—and this is something you don't want to call your game—"not an adventure game." Publishers don't want adventure games these days. So we're having to conform a little, but we're doing it in our own little rebellious way.

And we've got some ideas, one in particular, that's got a couple of variations. One's a little darker, and one is definitely on the humorous side. So it gives us a chance to stretch a little, take a breath, have some fun—or do something a little more serious, depending on which way the publisher skews, but very different from what's been in the **Myst** series.

From the Fans

"Rand Miller's greatest asset is his undying enthusiasm for the worlds he has helped create over the past dozen years. In print or in person, he always expresses the wonders of exploration and discovery that characterize Cyan World's games. His only maddening quality is his ability to keep all those game-related secrets. The tidbits of random information floating around his head could keep fans happy for decades, if only there were some way to get them out. Whatever Rand has next up his sleeve, count me in."

—Mark "Zardoz" Plummer, Washington
Myst fan since age 40

Q: This has got to be an exciting time for you. It's the first time in, what, 12 or 13 years that you're not working on a **Myst** game?

A: Yeah, oh yeah. It's a lot of fun, starting with a blank page. And in fact, the one project that's got a humorous aspect to it is frankly the one that everybody here is most excited about. There's some great potential there for doing things in a game that people haven't done before, given our little rebellious twist thing that we always like to do. And we've laughed a lot over the potential for this one. I think people would love it. And I honestly think that somebody's going to snatch it up, and they'll be happy they did. I think it'll do really well.

Q: Is it an all-ages game, or a children's game?

A: It'll definitely be all ages. I think the darker one might tend more toward a teen audience, but the lighter one would just be a blast for everyone. It might even have guns...but maybe with a little twist.

